

Cozy

MARK IV

Owner's Manual

Revision 05

November 3rd, 2024



Registration: N83MZ

Serial Number: 386

Owner: Marc J. Zeitlin

Builder Information

REGISTRATION NUMBER: N83MZ
BUILT BY: Marc J. Zeitlin
ADDRESS: 23501 Fir Drive
Tehachapi, CA 93561

DATE OF MANUFACTURE: August 2002
DATE OF FIRST FLIGHT: August 4th, 2002

ENGINE TYPE: Lycoming O-375-A2A
ENGINE S/N: Aerosport Power 0169
TTE AT INSTALLATION: 0.0 (was O-360-A2A)

Current Owner Information

CURRENT OWNER: Same
ADDRESS: Same
PURCHASE DATE: N/A
TT AIRFRAME AT PURCHASE: N/A
TT ENGINE AT PURCHASE: N/A
TT PROP AT PURCHASE: N/A

Table of Contents

Builder Information	2
Current Owner Information	2
Table of Contents	3
MANUAL NOTE	7
MANUAL WARNING	7
General COZY MKIV Description	8
DIMENSIONS	9
COZY MKIV 3-VIEW	10
FLYING QUALITIES	11
UTILITY	11
WEIGHTS	12
ENGINE & PROPELLER	12
LANDING GEAR	13
COCKPIT	13
FUEL SYSTEM	15
FUEL ADDITIVE CAUTION	16
CONTROL SYSTEM	16
BRAKE SYSTEM	16
TRIM SYSTEM	17
LANDING BRAKE	17
ELECTRICAL SYSTEM	18
Normal Operations	19
PILOT POSITION	19
BOARDING	19
ENGINE START	20
TAXIING	20
TAXI/CANOPY CAUTION	21
TAKEOFF	21
TAKEOFF CAUTION	21
CROSSWIND TAKEOFF	22
SHORT FIELD OBSTACLE CLEARANCE	23

ROUGH FIELD CAUTION	23
ROUGH FIELD CAUTION	24
HIGH DENSITY ALTITUDE	24
CLIMB	24
CLIMB CAUTION	24
CRUISE	24
CRUISE NOTE	25
DESCENT	25
LANDING	26
LANDING CAUTION	26
LANDING GEAR SPEEDS	27
LANDING GEAR CAUTION	27
NOSE GEAR CAUTION	27
TIP BACK CAUTION	27
GROUND HANDLING AND TIE DOWN	28
LOW SPEED HANDLING AND STALL	29
Low Speed Handling	29
Stall Characteristics	29
STALL CHARACTERISTICS NOTE	30
Emergency Procedures	32
FIRE	32
ENGINE FAILURE	32
ENGINE OUT APPROACH	33
DITCHING IN WATER	33
IN-FLIGHT CANOPY OPENING	34
LANDING GEAR FAILURES	34
WHEEL BRAKE FAILURE	35
FLIGHT LIMITATIONS	35
PLACARDS:	36
ENGINE LIMITATIONS*	37
LYCOMING O-375-A2A (from Operator's Manual)	37
Pilot Experience Requirements and Checkout	38

Weight and Balance	40
FORMULA	41
Weight & CG Limits	43
APPENDIX I: (Initial Systems Checkout)	44
GENERAL	44
CONTROL SYSTEM	45
LANDING GEAR	46
Main Gear	46
Nose Gear	46
INSTRUMENTATION	47
POWERPLANT	47
FUEL SYSTEM	48
FUEL GRADE CAUTION	48
Non-100LL FUEL CAUTION	48
WEIGHT AND BALANCE	49
EMPTY WEIGHT & C.G. LOCATION	51
WEIGHT AND BALANCE CAUTION	51
MAXIMUM GROSS WEIGHT CAUTION	51
MGW NOTE	51
APPENDIX II: (Flight Test Procedures)	52
GROUND TESTING	54
LOW SPEED TAXI	54
HIGH SPEED TAXI & NOSEWHEEL LIFTOFFS	55
FIRST FLIGHT	56
FIRST FLIGHT NOTE	57
ENVELOPE EXPANSION	58
FLIGHT - FLUTTER ENVELOPE EXPANSION	59
FLUTTER TEST CAUTION	60
APPENDIX III: (Maintenance / Inspection)	60
COMPOSITE STRUCTURE	61

PLEXIGLASS CANOPY	62
SCHEDULED MAINTENANCE/INSPECTIONS	63
Every Preflight (in addition to checklist items)	63
Every 25 Hours	63
Every 50 Hours	63
EXHAUST SYSTEM NOTE	63
GENERAL 50 HOUR INSPECTION NOTE	63
Annual/100 Hours	64
COMPOSITE CONSTRUCTION NOTE	64
Canard Removal	64
Canard Installation	65
Wing Removal	65
WING REMOVAL CAUTION	65
Wing Installation	66
APPENDIX IV: (FAA Records)	67
APPENDIX V: (Performance Data)	68
To Determine Density Altitude	68
Prototype Takeoff Distance Curves	68
Prototype Climb Speed Curves	70
Maximum Speed – Level Flight	72
Prototype Cruise Data Curves	72
Prototype Range Curves	73
To Calculate Range:	74
Prototype Glide – Gear Up Curves	75
Prototype Sink Rate – Sea Level – Gear Up Curves	75
Prototype Landing Distance – LB Extended	76
MARK IV Mandatory Changes	77
EQUIPMENT LISTS	78
Pitch Stability Determination	78
Revisions:	79

MANUAL NOTE

The information in this manual is based on the generic Cozy Mark IV owner's manual as written by the designer, Nat Puffer, but has been edited to be specific to the configuration and modifications made by the builder and owners of N83MZ. Use of this manual for any other aircraft is at the reader's risk and the author is not liable for any injury or damage to persons or property that occurs due to differences between N83MZ and another aircraft. Any further modifications to N83MZ may alter the applicability of this manual until testing has verified and updated the data contained herein.

MANUAL WARNING

This manual is obsolete unless updated by additions and/or corrections in newsletters #44 onward.

General COZY MKIV Description

The Cozy Mark IV is a compact, efficient, high-performance, high utility canard pusher 4-place airplane. It can accommodate a larger than average couple in the front and an average size couple in the rear. It features full dual controls and an expansive instrument panel.

N83MZ is equipped for night and IFR flying.

N83MZ is fitted with a 185 hp Lycoming O-375-A2A engine equipped with electronic fuel injection and dual electronic ignition. Two electric redundant fuel pumps are installed.

N83MZ is equipped with a dual alternator and dual battery powered electrical system based on Bob Nuckolls' Aeroelectric Connection diagram Z-14. It also has a lightweight electric starter.

The cockpit layout is designed to complement pilot and/or copilot work load, with throttle and oil cooler louver levers; a mixture adjustment knob; electric pitch trim, electric roll trim, electric landing brake, dual landing/taxi lights, electrically powered nose wheel extension and retraction with manual crank backup, exhaust muff cabin heat, electric seat heaters, a fuel tank selector valve located for equal access to both pilot and copilot, and individual side stick controllers on both outboard armrests. Adjustable rudder pedals are provided on both sides, and the brakes are actuated by further extension of the rudder pedals. Seating provides armrest, lumbar, thigh and head support for "recliner-chair" comfort not found in conventional aircraft seats. This allows long, fatigue-free flights.

The Cozy Mark IV uses the very latest aerodynamic technology, combining Whitcomb style winglets, a high-aspect ratio wing with a modified Eppler 1130 airfoil optimized for efficient cruise, an MS1145 Roncz canard airfoil and a configuration with far less wetted area than conventional airplanes. Because its power-off glide angle is only 4.4 degrees (~13:1 Glide Ratio), a belly mounted landing brake is used to steepen descent to a landing.

DIMENSIONS

Wing Span / Area:	28.1 ft (8.6m) / 88.3 sq. ft (8.2 sq. m)
Canard Span / Area:	12.1 ft (3.7m) / 13.1 sq. ft.(1.2 sq. m)
Total Wing Area:	101.4 sq. ft. (9.4 sq. m)
Length:	17.0 ft. (5.2 m)
Height:	7.9 ft. (2.4 m)

Cockpit Width:

Front:	42.0 in (1.07 m)
Rear:	38.0 in (0.97 m)

Cockpit Height:

Front:	38.0 in (0.97 m)
Rear:	37.0 in (0.94 m)

Cockpit Length:

Front:	70 in (1.78 m)
Rear:	54 in (1.37 m)

COZY MKIV 3-VIEW

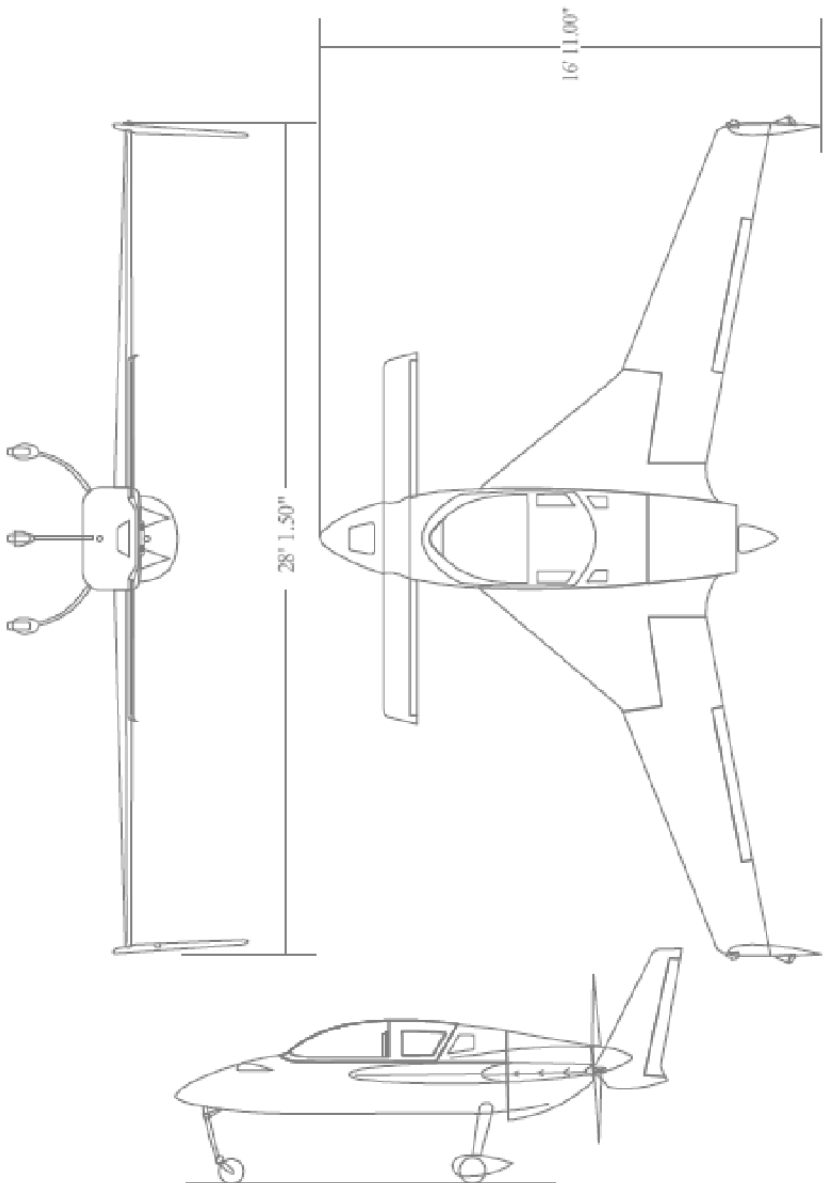

Figure 1: Cozy MKIV 3-View

FLYING QUALITIES

The COZY MARK IV has superb flying qualities. It is a very solid, stable airplane that has responsive ailerons, good turbulence resistance, excellent "hands-off" stability, and docile stall characteristics. It resists stall or spin even when maneuvered sharply to full aft stick. Flight tests with the prototype and plans model show it to be free from stall departures and spins when operated within the approved c.g. range. Climb is excellent, even at full aft stick speed. Trim changes due to power, gear retraction, or landing brake are all very small.

N83MZ approach and landing speed are 80 KIAS and 65 - 72 KIAS respectively at normal landing weights. The approach and landing are docile and conventional. Forward visibility is excellent even during touchdown.

UTILITY

The Mark IV has exceptional efficiency, speed and range and with its side-by-side seating, large instrument panel, and full dual controls, the passenger can assist with piloting and/or navigating duties, making long trips more enjoyable and less fatiguing. More complete instrumentation and navigation aids add a margin of safety on long trips, particularly if deteriorating weather is encountered enroute.

Range will depend upon the cruise speed selected.

Cruise at 8,500 ft. and 2600 rpm results in 143 - 145 KIAS / 166 - 169 KTAS with a LOP fuel burn of ~8.3 gph. With full fuel (56 gals), no-wind range is ~1000 nm (1,150 SM) in ~5.8 hours with a 30 minute VFR reserve.

Higher/slower will result in longer range operations - conversely, lower operations will require more power and possibly rich of peak operation.

The Mark IV is neither suitable nor recommended for operations from unprepared surfaces (i.e. gravel, loose dirt, or rough fields).

The Mark IV requires management of front seat loading within predetermined limits as discussed below and in the ["Weight & Balance"](#) section.

WEIGHTS

Empty weight for N83MZ is 1,259 lbs. The maximum allowable gross weight for takeoff is 2,175 lbs.

The front seat, because of its location approximately 40 inches ahead of the acceptable c.g., will have a minimum and maximum weight limit which will be determined for each airplane after completion as part of the weight & balance. Most pilots flying solo would not meet the minimum front seat weight requirement and would have to add ballast to the ballast compartment provided in the nose. The ballast compartment is approximately 2.3 times farther ahead of the c.g. than the front seat, so ~40 lbs. of ballast in the nose makes up for ~90 lbs. in the front seat. N83MZ has a 238 lb minimum and 407 lb. maximum front seat limit with no ballast and VFR reserve fuel. N83MZ can accommodate up to 43.5 lb ballast in the nose compartment, reducing the front seat minimum weight limit to 160 lb, and the maximum (with 43.5 lb ballast installed) to 313 lb.

The back seat can structurally accommodate as much weight as the gross weight of 2,175 lbs. allows. The back seat is centered at F.S. 101, so weight centered there is very close to the c.g. range and will not substantially affect balance.

Total loading of aircraft with people, baggage, and fuel must meet both c.g. and gross weight limitations.

NOTE: Maximum allowable gross weight for takeoff is affected by density altitude and runway length, and must be individually determined for each particular aircraft.

ENGINE & PROPELLER

The Cozy Mark IV was designed to use 4-cylinder Lycoming engines of 160 to 180 hp. This includes most models of the O-320, O-340 and the O-360 (It is suggested that models with 6th and 8th order counter weights be avoided). Only the light-weight, fixed-pitch, solid wood propellers are approved. N83MZ is fitted with an O-375-A2A 185 HP engine and a Hertzler/Persson Silver Bullet 2-blade composite fixed pitch 66" (diam) x 78" (pitch) propeller with a solid wood core. Constant speed, variable pitch or

metal propellers are not recommended due to weight, CG, and maintenance requirements.

The Hertzler/Persson propeller uses a urethane leading edge to minimize rain erosion and has an efficiency close to the best metal propellers, while offering a solution to the fatigue problem.

LANDING GEAR

The Mark IV features a tricycle landing gear with fixed mains and a retractable nose wheel.

The main landing gear is a one piece, molded S-glass/epoxy unit which gives exceptional energy absorption for bounce-free landing. N83MZ is equipped with gear leg and gear leg/fuselage intersection fairings. The main landing gear uses Matco 5-inch wheels and triple puck brakes with 5.00 x 5 Desser Monster Retread tires. The main wheels are streamlined with wheel pants.

The retractable nose gear strut is also molded S-glass and is electrically actuated by a simple switch in the front cockpit. An automatic extension system, measuring IAS, throttle position and AGL is installed to extend the nose gear in the case of pilot error. The nose gear is retracted in flight for optimum performance and also on the ground to provide nose-down parking. This stable, self-chocking parking position allows easy entry for a back seat passenger. Nose gear position is displayed to the pilot through acrylic windows through which they view the nose wheel directly. The nose wheel is 4-inch and uses a 10/3.50 x 4 6-ply tire.

N83MZ is equipped with a gear-warning indication on the EFIS which alarms if the gear is up and the throttle retarded, as well as the aforementioned automatic extension system based on IAS, throttle position and altitude AGL.

COCKPIT

Both the front and rear cockpits are exceptionally comfortable. Semi-reclined seating is provided for optimum pilot and passenger comfort. Although the front seat will physically accommodate a pilot or passenger 6 ft. 4 in. tall weighing more than 200 lbs. in comfort, the combined weight of pilot and passenger in the front seat should not exceed 407 lbs. The rear seat can accommodate

any combined passenger and luggage weights as long as CG and MGW limits are within compliance.

Full flight controls are provided on both sides in the front seat. Wrist-action control sticks are positioned on both the right and left side consoles, enabling the airplane to be flown from either seat, and enabling the pilot to relax and rest the weight of his (or her) arm on the side console, reducing workload on long trips. Throttle, mixture and oil cooler louver controls are located in the center console. The landing gear and landing brake switches are located in the center of the instrument panel.

The pitch and roll trim controls are located on both control sticks, as is the Push-To-Talk (PTT), Take-Off-Go-Around (TOGA) and A/P disconnect switch.

Storage pockets are provided at both sides of the front seat in the armrests for miscellaneous objects.

The rear seat leg areas are wide enough to store luggage even when the seats are occupied with passengers. Additional storage space is available in the strakes.

Due to the highly insulated fuselage structure and the large acrylic canopy, N83MZ will maintain about 30 degrees F above ambient temperature (vents closed, sun shining). Thus the requirement for cabin heat is far less than other light planes.

An exhaust heat muff heating system is provided in N83MZ for those who intend to fly in winter in cold climates, with a heat control knob push-pull cable between the pilot and co-pilot on the seatback above the fuel selector valve.

Due to the small cabin volume, effective ventilation system and altitude capability, the Mark IV is also more comfortable in hot weather than conventional light-planes.

N83MZ is equipped with an EFIS displayed alarm which warns the pilot when advancing the throttle for takeoff with the canopy unlatched. A canopy safety latch is installed as a back-up, to catch the canopy if the pilot neglects to lock it and ignores the warning system.



Figure 2: N83MZ Instrument Panel & Control Arrangement

FUEL SYSTEM

N83MZ's fuel system consists of two 28 gallon individually selectable wing tanks. A three way duplex selector valve (left, right, off) is located in the center of the front seat back. There is no provision for cross feed so fuel can be used from only one tank at a time.

Two fuel sump blisters located under each fuel tank at the fuselage juncture assure fuel supply to the engine in all normal flight attitudes. Each tank is individually vented with two vents - one in the plans position near the fuel cap for level operation and one in the rear of the tank for nose down venting. All vent lines traverse the top of the firewall and exit under the strake. Redundant electric fuel pumps transfer fuel from the tanks to the SDS electronic fuel injection system. Fuel pressure is indicated on the Dynon EFIS display in the cockpit. The 2nd electric pump should be turned on if the primary pump fails as indicated by a loss of fuel pressure. Both electric fuel pumps should be used to provide fuel pressure redundancy during low altitude operations such as takeoff and landing.

There are two fuel drains on the airplane, one in the leading edge of each fuel tank strake. To prevent overfilling the fuel tanks, exceeding the gross weight limitations, the tanks can not be completely filled with nose down parking. To fill the tanks to the full 56 - 58 gallon capacity, the nose wheel must be extended to

level the aircraft. Be careful to hold the nose down during this operation or ensure that ballast is installed in the nose. The nose can be lowered after full up fueling with the caps on without leaking. However, heat expansion may force fuel out the vents. Filling to the full capacity should be done only when required for extended-range trips and as close in time to takeoff as possible.

FUEL ADDITIVE CAUTION

Fuel additives should be checked for compatibility prior to use. Some fuel additives such as MEK, and deicing fluids like "Canned Heat", and auto gas with alcohol (especially the high aromatic content, no-lead) should **NEVER** be used. Even extremely small amounts of dissolved epoxy can damage the fuel system.

CONTROL SYSTEM

Pitch is controlled by a full-span canard slotted flap (elevator) providing a large allowable c.g. range. Roll is controlled by conventional ailerons on the rear wing. The cockpit controls are similar to most aircraft with pitch and roll controlled by the side sticks and rudder pedals for yaw. The side stick controllers are employed to give the pilot the smallest workload control arrangement possible. The rudders, located on the winglets at the wing tips, operate outboard only, providing two totally independent systems. The rudders are used singly for yaw control or can be deployed together as a mild speed brake.

BRAKE SYSTEM

High Capacity Matco triple-puck brakes are provided on the main wheels. They are used together for deceleration on the ground and individually for directional control at low speed on the ground. The brake actuating mechanism is the rudder pedal; after full rudder deflection is reached, the brakes are actuated. This system aids in keeping brake maintenance low by ensuring that full aerodynamic control or braking is employed before wheel brakes are applied.

While a brake system parking valve is available, on flat ground the parking brake is provided by the rubber bumper on the nose gear (nose down parking). If it should ever be necessary to hand prop

the engine to get it started, it should be done with the aircraft parked nose down, the parking brake engaged and a knowledgeable assistant tending the throttle.

TRIM SYSTEM

Cockpit-adjustable trim is provided for pitch and roll only. Electric pitch trim is provided using the Alex Strong system with a '4-way' hat switch on each side stick. The actuator (motor) is fitted to the elevator control rod located just forward of the IP on the pilot's side fuselage wall.

Roll trim is an electric actuator moving the plans spring system. Adjustable aerodynamic trim tabs are not used. The pilot can safely override any trim setting even if stuck in an extreme position. The pitch trim can trim to hands-off flight from minimum to maximum speed.

The Dynon Autopilot Controller will restrict trim motion to no more than 5 seconds at a time to prevent trim runaway in the event of a stuck trim switch (or an error-prone or inattentive pilot).

LANDING BRAKE

A drag device is used to allow a steeper approach and to provide more deceleration in the flare. This belly-mounted landing brake is deployed by an electric switch on the lower center IP. It is normally extended on final approach after gear extension and left down until after landing. Maximum allowable speed with the airbrake down is 90 KIAS. The brake does not affect stability, canard stall speed, or canard stall characteristics and has only a mild effect on pitch trim. The brake significantly interferes with the airflow passing into the engine cooling NACA duct and engine temperatures will likely exceed safe limits if the throttle is set above 1,500 RPM with the brake extended. During touch-and-goes and go-arounds the Landing Brake **MUST** be selected **UP** before the throttle is advanced to full power. Climbs should be avoided with the brake down, as engine cooling and climb performance are reduced.

N83MZ is fitted with a circuit that will retract the landing brake upon >90% throttle application and will latch the landing brake in

the up position until the landing brake switch is moved into the “commanded up” position, at which time it can again be “commanded down” with the switch.

The brake induces a mild buffet when down. During landing and taxi leaving the landing brake down provides some propeller protection from foreign objects kicked up by the nose wheel.

ELECTRICAL SYSTEM

The following documents define the electrical system in N83MZ.

- [N83MZ Electrical System Bus Maps](#)
- [+12V Power Schematic](#)
- [Stein IP schematic](#)

which are all available on “Google Drive”. The system is closely based on Bob Nuckolls’ Aeroelectric Connection diagram Z-14, and included dual batteries, dual alternators, dual ATO fuse buses under the front seats, a B&C field of tabs ground bus under the co-pilot’s seat, dual master contactors, and a cross tie contactor. Fuse and ground buses on the interior firewall supply power to the aft components. The system has two EarthX ETX-680C batteries, a B&C L-60 alternator, a B&C BC462H vacuum pump pad alternator and B&C voltage regulators for each bus.

Normal Operations

This section covers the normal operating procedures for the Cozy Mark IV. A pointer to the full checklist is provided at the end of this manual for more convenient cockpit use. Detailed loading information and performance data are provided in the W&B and Performance sections of this manual.

PILOT POSITION

The Mark IV was designed to accommodate tall pilots up to 6 ft. 4 in. Short pilots can fly the aircraft but they may need to sit on a cushion to position their eyes in about the same position as tall pilots in order to have adequate forward visibility. The adjustable rudder pedals should be set in the aft position for short pilots and they should use cushions as required to ensure adequate visibility during climb and landing flare. Confirm that the pilot's head is within 1" of touching the canopy before flight.

BOARDING

Pilots flying solo will need to add appropriate ballast to the rear nose door compartment for acceptable c.g. (see "[Weight & Balance](#)").

To maneuver the airplane by hand on the ground, raise the nose approximately 24" ($\frac{2}{3}$ up) using the electric nose gear extension switch. Once the nose wheel is partially extended check for adequate nose weight by gradually lifting the canard until the balance or tipping point is felt approaching. **DO NOT** lift the nose beyond this balance point or the aircraft may uncontrollably tip backwards onto its tail, likely damaging the lower winglets, the propeller and the wheel pants. While lifting the canard, always be ready to quickly lean on the top of the canard with the shoulder and chest area to prevent the airplane from tipping backwards if the tipping point is inadvertently exceeded. Once ground handling is completed, lower the nose fully by retracting the nose wheel to reduce the chances of both inadvertent tipping and uncommanded movement due to surface slope. **DO NOT** attempt to raise or lower the nose with the backup mechanical nose wheel crank with any weight on the nose gear.

ENGINE START

N83MZ is equipped with a light-weight B&C electric starter. Before starting the engine, the pilot should make certain that no one is standing in the vicinity of the propeller and clearly call out “clear” before engaging the starter.

If it is ever necessary to start the engine by hand-propping, it should be chocked by parking nose-down and have the brakes applied with the parking brake on. Throttle should be set to no more than that required for 1,000 RPM. Hand-propping a Mark IV is theoretically safer than hand-propping a tractor type (engine in front), because you don't have to reach through the propeller to grasp the trailing edge of the blade, the airplane doesn't tend to come toward you after the engine starts, and the airflow through the propeller doesn't tend to suck you in. Nevertheless, one should be extremely careful when hand propping.

Starting N83MZ involves turning on both batteries, waiting until the Dynon EFIS displays engine parameters, turning on both E.I. coils, turning on one fuel pump, pumping the throttle three times, verifying the mixture knob is at 0% and then depressing the **START** switch. Use special care that the propeller is clear before starting. The Mark IV attracts a lot of attention, and people like to stand around and watch. Announce loudly and wait for a response and time for people to get out of the way. If possible, have an observer confirm that the propeller is clear prior to starting.

After start, the engine should be idled at ~750 - 1,000 RPM. Oil pressure should rise to within idle limits (>25 psi) within 30 seconds after starting.

STARTING NOTE

Attempting to start the engine with the nosewheel fully retracted and with low fuel contents is not advised as the fuel pickup in the tanks may be exposed, leading to fuel starvation during or shortly after start. This has been observed in N83MZ with <3 gallons in each of the wing tanks (6 gallons total).

TAXIING

On unprepared loose surfaces, or wherever there is loose debris, keep taxi speed slow. Pusher type aircraft are more susceptible to propeller damage than tractor type aircraft. Lowering the landing brake while taxiing may provide some propeller protection.

Steering below ~30 knots (35 mph) is accomplished by applying full rudder and modulated braking as required in the direction you wish to go. As you accelerate, the single pedal control will automatically shift you to rudder steering as the rudders become increasingly effective. The nose gear will free swivel, enabling you to maneuver in very tight places with ease. At low speed, steering is done exclusively with differential braking. The geometry of the Mark IV makes it much less sensitive to upset than most aircraft. Comfortable taxiing operations have been demonstrated in 40 knot crosswind components. Be careful to hold the stick while taxiing downwind so the "tailwind" won't damage the ailerons or elevators.

TAXI/CANOPY CAUTION

When taxiing in a strong wind, an open canopy may have an adverse effect on steering, and the wind may put undue stress on the canopy hinges. It is better to close and lock the canopy when taxiing in winds above 15 kts.

TAKEOFF

Complete the pre-takeoff checklist. Check static RPM at full throttle. It should be approximately 2350 - 2450 RPM for normal takeoff performance. Double check the fuel valve is **fully** open on either tank and the canopy is locked down. Taxi forward a few feet to straighten the nose wheel. Set pitch trim for takeoff.

Apply full throttle smoothly. As the aircraft accelerates, use rudder and brake as necessary for directional control. Maintain slight aft stick pressure while accelerating to relieve the weight on the nose wheel. Passing through 70 KIAS, rotate smoothly to the correct attitude. Add 5 knots if operating at heavy gross weights or forward CGs.

TAKEOFF CAUTION

NEVER rotate the nose beyond the angle that places the canard on the horizon. This is to avoid the possibility of the propeller striking the ground.

CROSSWIND TAKEOFF

During takeoff ground roll, with a crosswind component above 10 knots, you will find that wheel braking may be required long into the ground roll for directional control. In stronger crosswinds you may require braking almost up to rotation speed. The best technique is to hold full rudder but not to ride the brake continuously. Apply downwind brake intermittently and allow the aircraft to accelerate between applications. The takeoff ground roll can be extended significantly (50% or more) by strong crosswinds, especially at high density altitudes and high gross weights. The braking requirement for directional control is the reason for the takeoff limitation of 15 knots crosswind. Landings can be made up to a 20-knot crosswind component.

CROSSWIND TAKEOFF TECHNIQUE #1: Hold aileron into the crosswind as you accelerate. Brake intermittently. Accelerate above normal rotation speed and then rotate the nose abruptly to make a clean lift off without side-skip. For crosswind components above 10 knots, add 5 knots plus one half the gust factor to the normal rotation speed. When clear of the ground, make a coordinated turn into the wind to correct for drift and to maintain a straight track over the runway.

CROSSWIND TAKEOFF TECHNIQUE #2: If the width of the runway allows, line up as far on the upwind side of the runway as possible, pointing at a 30 degree angle toward the downwind side of the runway. Allow the crosswind to turn the plane into the wind as you accelerate. Also hold aileron into the crosswind as you accelerate. Brake only as required to avoid runway excursions. By the time the crosswind has turned the plane into the wind, rudder control should be available and no braking required for steering. Then continue the takeoff as above.

SHORT FIELD OBSTACLE CLEARANCE

Reduce gross weight as much as feasible and check the c.g. to ensure it is not so far forward as to delay rotation - the further aft the c.g., the better, within the approved range. Be sure the engine is thoroughly warmed up and taxi to the very end of the runway. Make sure the fuel selector valve is fully open. Align the aircraft with the runway, hold the brakes, and apply full power. Release the brakes and try to use minimum braking for directional control. Maintain neutral elevator until rotation. Rotate to lift-off at 65 KIAS (light weight) or 70 KIAS (heavy weight). Maintain 80 KIAS best angle of climb speed until obstacle is cleared, then accelerate to normal climb speed. See Takeoff Distances.

ROUGH FIELD CAUTION

Although the Mark IV uses 5.00 x 5 mains, a 10-inch diameter nose-wheel tire and a spring loaded shock strut, this does not make the aircraft suited for rough, gravel, or unprepared fields. Since the Mark IV is a pusher, it cannot be rotated as easily as tractor type aircraft which have a propeller blast across the tail. You still must accelerate to normal rotation speed of 70 to 75 KIAS, depending on c.g., before the nose wheel comes off and during this time the nose wheel can kick debris into the propeller. The high rotation speed and possible propeller damage makes the Mark IV less suitable for unprepared field operation than lower performance tractor types.

However, if using an unprepared surface, reduce gross weight as much as feasible and adjust the c.g. as far aft as practical (within limits) to allow an early rotation. Do not use high power with the aircraft stationary, do the mag check on the roll if necessary. Hold full aft stick and apply power gradually to start the aircraft moving before coming in with full power. This technique will help minimize propeller damage. As the nose raises, the elevator should be eased forward so the nose wheel is held just clear of the ground. Accelerate and lift off at the normal speed and accelerate to the desired climb speed. Don't try to "jerk" the aircraft off prematurely; this only places the propeller closer to the ground and increases the chance of damage.

ROUGH FIELD CAUTION

Operation from grass fields, even if smooth, is not recommended. The additional rolling resistance will extend the takeoff roll. Even with 5.00 x 5 tires and the shock strut, most grass fields will punish the gear more than hard-surfaced runways.

HIGH DENSITY ALTITUDE

At density altitudes above 3,000 ft., follow the normal takeoff procedures except (1) lean the engine for best power during run up and (2) let the aircraft accelerate to 75 KIAS before smoothly rotating and lifting off.

CLIMB

Approximate climb performance data is given toward the end of this manual. For optimum rate of climb, maintain ~90 KIAS. Best angle of climb is obtained at ~80 KIAS. For better visibility and improved cooling, use a normal cruise climb of 100 KIAS - 130 KIAS. Climb performance is improved with the nose gear retracted (although not drastically) and it should be retracted once your initial climb is established.

CLIMB CAUTION

The altitude capability of the Mark IV far exceeds the physiological capability of the pilot. Use oxygen per 14 CFR Part 91.211 (or at lower altitudes) as required when operating at higher altitudes.

CRUISE

The maximum recommended cruise power setting is 75%. However, to take the best advantage of range and fuel economy, you may find that cruise power settings as low as 45% get you to your destination faster by avoiding fuel stops. Cruise at 60% - 65% power is the best compromise, providing good speeds and significant lowering of engine noise at cruise. Below 75% power, the SDS EFII system will lean the mixture aggressively to obtain desired RPM. Note that the best range is obtained at a very low speed and the best balance between range and speed is obtained at

the Carson Speed, which for the COZY MKIV is approximately 100 KIAS.

Maneuvering speed (V_A) is 120 KIAS at MGW and reduces at lighter weights. Remain below this speed in rough air.

Check the fuel level in each tank occasionally. Switch tanks to maintain a reasonably balanced fuel load - the Dynon EFIS will suggest a fuel tank change after every 10 gallons of fuel usage. If possible, select an unused tank only when a forced landing can be easily accomplished (in case the valve malfunctions or there is water in the newly selected tank). Always try to be within range of a suitable landing place with the fuel in the tank in use until you verify that you can select and use the fuel in the other tank.

Once at cruise altitude in smooth air, trim the aircraft to allow hands-off cruise. It is much less fatiguing to fly by making an occasional small adjustment of trim than to fly by continuously holding the stick. After a little practice setting trims, you will find you will be doing most of your flying including climb and descent without holding the stick. The rudder pedals are designed to allow the pilot to tilt his feet inward, slide them forward of the pedals, and relax in a stretched out position. This places the weight of the thigh on the thigh support rather than on the tail bone and greatly increases comfort on long flights.

Use the Dynon 2-axis autopilot to lower pilot work loads as desired.

CRUISE NOTE

The Mark IV employs the Roncz MS1145 canard airfoil, which unlike the GU canard on the Varieze, Long-EZ and COZY III is minimally affected by visible moisture (rain) or contamination.

DESCENT

The COZY Mark IV has such good climb performance that routine use of higher cruising altitudes to avoid turbulence discomfort will occur more often than with most light aircraft. It is not unusual or inefficient to climb to 12,000 ft. altitude for a 150 mile trip, for example. Plan the descent into the destination enough in advance so that a reasonable descent rate can be maintained. The Mark IV is a clean airplane and even with power at idle, it may take

substantial time to descend. Using the extra altitude for a cruise descent speed advantage will decrease trip time. Start the descent about 6 miles from your destination for every 1,000 ft. of altitude to lose, to arrive at pattern altitude.

LANDING

Make the approach and traffic pattern very cautiously. Most pilots and controllers are accustomed to looking for more conventional aircraft and may ignore you completely. Others may think there is enough room to sneak in ahead of you. Best pattern speed is 80 to 85 KIAS, slowing to 80 KIAS on final approach (a little faster in turbulence or gusty winds). The Mark IV is a very clean airplane and you can double the runway length required if you are 5 or 10 KIAS fast on your approach.

Deploy the landing brake on base or final as required to obtain a normal glide path angle comparable to conventional aircraft. Failure to use the landing brake may result in a flat/wide pattern, more difficult airspeed control and the possibility of overshooting your desired touchdown point. Hold an appropriate attitude and touch down between 65 - 70 KIAS. The normal landing technique of holding the nose off to minimum speed should **NOT** be used in the Mark IV. Obtain the correct attitude while entering ground effect and then fly it down to touch down. This avoids a common tendency to flare too high or too much.

Maintain a slightly nose high attitude as you roll out and use aft stick to ease the loads on your nose wheel during heavy braking. While the landing gear is strong enough for rough surfaces, the small tire diameters will give the crew a harsh ride. This, combined with the 65 KIAS touchdown speed, makes a hard surfaced runway much more pleasant. If you need to land on a rough field, hold the aircraft off to minimum speed and keep the nose high as long as possible.

LANDING CAUTION

Never flare beyond the angle that places the canard on the horizon. This is to avoid the possibility of the propeller striking the ground. Also, if slips are employed in the landing pattern, always slip so that the fuel tank in use is on the high side of the slip.

Crosswind landings may be flown several ways. Mild crosswinds are easily handled using the wing-low, side-slip approach. Another method is to simply land in a wings-level crab. The landing gear design makes his technique safe and easy. The best method for strong gusty crosswinds is to approach in a wings-level crab and straighten the nose with the rudder immediately before touchdown. Be careful not to lock a wheel brake (full rudder) at touchdown. The Mark IV has demonstrated taxi, takeoffs, and landings in gusty winds to 45 knots and with crosswind components as great as 18 knots for takeoff and 28 knots for landing.

Fly from long runways until you develop your proficiency. The following runway lengths can be considered as minimums, but only after you have made at least 20 landings on longer runways:

- With landing brake 1,800 ft.
- Without landing brake 2,400 ft.

LANDING GEAR SPEEDS

With the electric extension system the nose gear can be extended or retracted at speeds up to 140 KIAS. If the electrical extension system fails, the air loads make it hard to extend the nose gear at high speed so reduce the airspeed to minimum practical when using the manual backup system. Put the “**Manual LG**” switch in the “**OFF**” position for manual usage.

LANDING GEAR CAUTION

If the c.g. is aft, it is possible to rotate the nose to an excessively high angle during landing rollout, placing the c.g. aft of the main wheels. Avoid rotation above 12 degrees (canard on horizon), using forward stick or brakes as necessary to avoid propeller damage or tipping the aircraft onto its tail.

NOSE GEAR CAUTION

If the nose gear mechanism is not lubricated or is binding or is not receiving sufficient electrical power, it may not extend fully. If this occurs, do not raise the gear again or continue to select the down position. Try using the mechanical backup system but do not force the handle. Slow down to minimum speed if necessary, to allow it to crank down easily. Fix the cause of binding before further flight.

TIP BACK CAUTION

With the nose gear extended and without a pilot or passenger in the front cockpit, or without ballast in the nose, the Mark IV will fall on its tail unless the nose is held down. The aircraft might initially sit on the nose wheel, but after the fuel bleeds through the baffles towards the aft of the tank, it will tip backwards. Be sure to brief all ground handlers that the aircraft can fall on its tail unless parked nose down and could get away from them while moving the aircraft. If the aircraft is subject to being moved by unknowledgeable people, ballast the nose or attach a sign to caution them about the possibility of tipping over.

Normal care of the main landing gear strut should include lifting one wing tip to allow the gear to spring inward ("set" the gear) when parking, especially in hot weather. This lowers the stress on the strut and reduces the possibility of gear creep and loss of alignment.

GROUND HANDLING AND TIE DOWN

The easiest way to handle the aircraft on the ground is to stand in front of the canard and grasp its top surface with one hand and the elevator slot underneath with the other hand. Do not handle the elevator. Leave the nose gear partially retracted for ground handling. The airplane balances best with the nose slightly lower than level.

The Mark IV can be safely left unattended, parked on the nose bumper, in moderate winds. However, it is prudent to always tie down any aircraft whenever possible. For long term parking, position the Mark IV backwards in the parking slot with the nose over the normal tail tie down rope. "Set" the main gear and securely tie down the wings.

For ground handling inside the hangar, use a little dolly with 3 or 4 casters to set the nose bumper on. The aircraft can then be maneuvered inside the hangar without lifting.

LOW SPEED HANDLING AND STALL

Low Speed Handling

The very low speed range of the Mark IV (below 70 KIAS) is characterized by a large increase of the force required to hold full aft stick, tending to keep the inattentive pilot at a more normal flying speed. Nevertheless, the Mark IV has good flight characteristics at these minimum speeds. When operated within its approved c.g. range, it is a docile, controllable airplane at full aft stick at its minimum airspeed of 60 to 63 KIAS. It does not exhibit any of the conventional airplane's tendencies to roll or pitch down uncontrollably, or other common uncommanded flight path excursions. Any power setting may be used at full aft stick without changing the way the airplane handles. By adjusting the throttle setting, you can climb, descend, or maintain level flight. Ailerons and rudder are effective at all speeds, including full aft-stick flight.

Stall Characteristics

Canard aircraft, such as the Mark IV, have two lifting surfaces, i.e. the canard and the main wing, so when one talks about "stall characteristics", one must distinguish between a canard stall and a main wing stall. In the case of a canard stall, the nose will drop a few degrees, speed increases and the aircraft keeps on flying. Even with power off, there is no sudden loss of altitude. The phrase "stall resistant" applied to a canard aircraft, means that in normal operation the canard will stall before the nose can be raised high enough to stall the main wing.

Aft c.g. flight testing of the Mark IV plans model showed that it was possible to stall the main wing at a c.g. of 101.5", which was inside the desired c.g. operating range of 97.5" to 102". However, it was demonstrated that by shortening the canard span 6", the main wing no longer stalled within the desired c.g. range, or even as far aft as 103.2".

Shortening the canard span to 6" less than that shown in the plans was a mandatory design change for all Mark IV builders and a notification published in Newsletter #44.

Aft c.g. flight testing also verified the need to install the lower winglets and vortilons shown in the plans to achieve the desired "stall resistance" over the approved c.g. range. The plans-built

Mark IV, with shortened canard, exhibits the following stall resistant characteristics:

- 1) Stabilized flight (climb, level, or descent, depending on power setting) at full aft stick. Below 70 KIAS, there is a very definite increase in the aft stick force, such that the pilot has to pull noticeably harder on the stick to get below 70 KIAS.
- 2) Occasionally, particularly at forward c.g., the airplane will oscillate mildly in pitch after full aft stick is reached. This is a mild "bucking" of very low amplitude, one to two degrees and about one-half to one "bucks" per second. If the full aft stick is relieved slightly, the bucking stops.
- 3) Occasionally, particularly at aft c.g., the canard will stall, the nose will drop about 8 degrees with wings level, the airspeed will increase slightly, and the canard will be flying again with no loss of altitude. Back stick pressure should be relaxed at this point. If it is not, the nose will rise again and inertia could carry it up to an even higher angle of attack before the canard stalls the second time.

At any time during the "stall" power can be set at any position, or moved to full or idle, without substantially affecting the stall characteristics. There is a small roll trim change due to power and very slight pitch trim change, neither affect the aircraft's controllability at sustained full aft stick.

Accelerated stalls or abused controls were not tested at aft c.g., nor was any attempt made to spin the Mark IV, which would have required stalling the main wing first.

Canard stalls are approved in N83MZ in any power, trim or landing condition within the normal operations envelope. Intentional spins (or attempts to spin) are not approved.

STALL CHARACTERISTICS NOTE

Some variation in stall characteristics may be expected from one airplane to another. Inaccurate airfoil shapes, incidence errors, or weight and balance errors can result in a degradation of the normal stall resistant characteristics. At some point aft of the aft c.g. limit, the Mark IV may be susceptible to a main wing stall which, while

easily recovered if forward stick is applied immediately, can result in a stall break with high sink rate.

Experience with other aircraft of similar configuration has shown that if the c.g. is far enough aft and the main wing is stalled and recovery controls are not employed soon enough (before the airspeed drops far below canard V_S), the aircraft could become "locked in" to a "deep stall" and recovery would become very difficult with a large loss of altitude. No attempt has been made to stall the main wing of the Mark IV and hold full aft stick until airspeed dropped to zero to see how easy or difficult the recovery would be.

Inadvertent deep stalls have occurred in a few instances due to flying aft of the rear CG limit, lack of fuel tank rear baffles, incorrect canard incidence angles, and lack of wing leading edge vortilons, or combinations of the above. All have been serious but not fatal.

Emergency Procedures

All Emergency Procedures and Checklists are found in the N83MZ Checklist document:

- [N83MZ Standard / Emergency Checklists](#)

also on “Google Drive”.

FIRE

There are normally only two sources of aircraft fires; electrical and fuel. In the event of fire on the ground, kill all electrical power and shut the fuel off. Clear the aircraft. Use a dry-type extinguisher. For in-flight fire, determine the cause. If electrical, all electrical power to the affected bus should be shut off. If fuel, turn the fuel selector off and electrical power off. Turn the cabin heat off and open the cabin air vent. Execute a precautionary landing as soon as possible.

ENGINE FAILURE

Modern aircraft engines are extremely durable and seldom fail catastrophically without plenty of advance warning (lowering oil pressure, excessive mechanical noise, rising oil temperature, etc.). Pilot induced failures, on the other hand, are far more common (fuel starvation, fuel management, etc.). In the event of in-flight engine stoppage follow the emergency checklist as documented above. If time and conditions permit, attempt a restart.

If the engine begins to run rough, check for improper mixture setting or ignition issues. If one ignition is bad, or an alternate mixture setting fails to correct the roughness, make a precautionary landing as soon as possible and troubleshoot. Lowering or rising oil pressure, rising oil temperature, or increasing mechanical noise are good indications of impending failure and the flight should be aborted as soon as possible. Don't hesitate to declare an emergency to obtain priority clearance. If stoppage does occur and restart is impossible, execute a forced landing.

ENGINE OUT APPROACH

If an engine-out landing is unavoidable, check wind direction, choose a landing area and if you have enough altitude and time, slow to 60 - 65 KIAS to allow the propeller to stop windmilling. Establish a glide at 75-55 KIAS. Remember that with the engine out and propeller windmilling the glide range of ~1.8 nm per 1000 ft will be considerably steeper than the normal engine-idle glide range of ~2.2 nm per 1000 ft to which you are accustomed. With a stopped propeller, the glide range will be ~2.0 nm per 1000 ft of altitude.

Tune in 121.5 MHz, declare an emergency and give your intended landing site. Shut off the fuel valve. Your landing gear should be down, even for an off-airport landing in rough terrain or water. This will cushion the landing and keep the nose from slapping down and digging in after the main gear hits. Your glide will be steepened and rate of descent increased with the gear down. Set up the forced landing pattern with the landing brake out and shoot for the middle third of the forced landing area. Therefore if you misjudge short, you can retract the landing brake and still make the field. Turn the electrical power and ignitions off before touchdown to minimize any potential fire hazard. Touch down as slowly as possible if landing in rough terrain and steer between any obstacles.

DITCHING IN WATER

When ditching, the object is to do it in such a way that the aircraft remains upright. This has been done successfully in a similar configuration at least once. The recommended procedure is as follows:

- Wear a life jacket for extended over water flying
- On descent, bend the safety catch away but do not open the canopy
- Extend the nose gear
- Touch down should be at minimum speed, landing into the wind
- Land on the back side of a swell or parallel to the swells

- The aircraft or major components of the aircraft should float and support the occupants and equipment due to the large amounts of structural closed-cell foam

IN-FLIGHT CANOPY OPENING

Canopy opening in flight qualifies as an emergency. With the canopy unlatch warning system and the safety catch, the likelihood of a canopy fully opening in flight is low. However, it can open to the safety catch, for example, if the latch is locked (in which case the horn won't sound) but the hooks have not engaged. If this is the case, the canopy will probably open to the safety catch immediately after rotation. Should this happen, **don't panic**. The aircraft is fully controllable. Simply reduce airspeed to minimize air blast, stay in the pattern and land.

The canopy generates a fair amount of lift, and it can open fully in flight if the latch becomes unlocked and the safety catch has been bent inward so that it does not engage. This has happened on more than one occasion. Concentrate on **FLYING THE AIRPLANE**, return to the field and land.

It is not possible to close and lock the canopy in flight without assistance in the back seat, as the lift on the canopy will prevent the rear hook from engaging. Concentrate on flying the airplane to the closest airport and landing before trying to lock the canopy.

LANDING GEAR FAILURES

Since only the nose gear retracts and its actuation system is so simple, failure to extend or retract properly is highly unlikely. A far more likely failure is the pilot neglecting to extend the gear even with the alarm annunciation. Should you find yourself gear up in the landing flare or even rolling along on the mains at 55 KIAS or more, you can easily hold the nose off to make a go-around or even extend the gear at that point. If you just can't avoid landing gear up, hold the nose off for as long (and slow) as practical, and then fly the nose to the runway. Avoid a nose-high canard stall, which would allow the nose to drop hard to the runway. It is good practice on the landing roll-out to glance at the nose gear window to verify that the gear is in fact down before the

canard stops flying. Damage from landing nose gear up should be minor and easily repaired.

The only other gear emergency to be considered is a flat tire. If you know that you have a flat/blown main tire, make a normal landing touchdown near the side of the runway with the good tire. Use ailerons to hold the weight off the flat tire. Lower the nose, use brakes for directional control, and try to keep the aircraft headed straight down the runway.

WHEEL BRAKE FAILURE

Since the brakes are the only means of directional control after the aircraft decelerates below about 35 knots, landing with a brake out poses a special kind of problem. The risk of damage can be minimized by considering the following: If possible, select a long runway with a cross wind from the side of the failed brake. The aircraft will weather-vane into the wind and by careful application of the good down-wind brake, directional control can be maintained. If it becomes obvious that the aircraft will leave the runway and enter rough terrain, or strike an obstacle, it might be preferable to retract the nose gear. This will scrape the bottom of the nose. However, this may be preferable to running into an obstacle.

FLIGHT LIMITATIONS

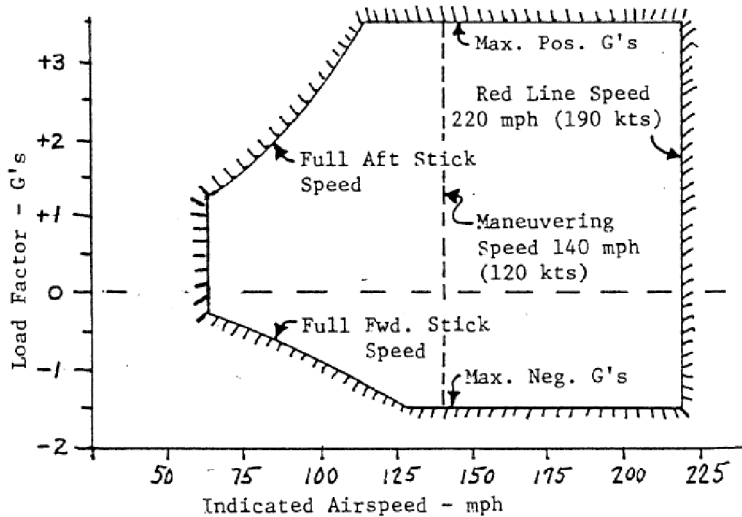

Figure 3: Allowable Flight Envelope

PLACARDS:

If desired, install these placards in the cockpit, visible to the pilot:

Min. Front Seat Weight (If less, add ballast) 238 lbs.

Max. Front Seat Weight 407 lbs.

Max. Gear extension speed 140 KIAS

Max. speed with gear down 160 KIAS

No aerobatic maneuvers are approved except those listed below:

Maneuver Speed *	Recommended Entry
Chandelles	130 KIAS
Lazy Eights	130 KIAS
Steep Turns	130 KIAS
Stalls (No whip stalls)	Slow deceleration
Accelerated Stall	110 KIAS
*Abrupt use of controls prohibited above	120 KIAS

Max. Crosswind component (Takeoff)	15 kts (17 mph)
Max. Crosswind component (Landing)	20 kts (23 mph)
Max. speed brake extension speed	90 KIAS (103.5 mph)
Max. indicated airspeed (Redline)	190 KIAS (220 mph)
Maneuvering speed, V_A	120 KIAS (140 mph)
Max. Gross Weight	2,175 lbs.
Max. Positive "G"	3.5 G
Center Gravity Limits	Fwd 97.5, Aft 102.0

Intentional spins (or attempts) not permitted.

ENGINE LIMITATIONS*

LYCOMING O-375-A2A (from Operator's Manual)

Rated HP RPM	2700
Rated Horsepower	185 hp
CHT (Never Exceed)	500 F (260 C)
(Continuous Ops)	150 F - 400 F (65 C - 205 C)
Oil Sump Acceptable Quantity	2-8 US Quarts, SAE 100W, 15W-50, 20W-50
Oil Temp (Max.)	245 F (118 C)
(Desired)	180 F - 215 F (82 C - 102 C)
(Min. Continuous)	165 F (74 C)
Oil Pressure (Max during warmup)	115 psi
(Normal)	55 - 95 psi
(Idle)	25 psi
Fuel Press. (Fuel pump outlet)	45 to 50 psi (engine off)
Compression Ratio	7.8:1 pistons (8.5:1 effective)
Fuel	94 Octane or higher

*Refer to specific engine's operator's manual for other detailed operating instructions and limits.

Pilot Experience Requirements and Checkout

There is no such thing as a minimum number of total hours a pilot should have to be qualified for checkout solo in a new aircraft. It would be nice to receive a dual checkout in another Cozy Mark IV. If this is not possible, do not worry. The best pilot qualification is variety. They should be current in more than one type of airplane. The Mark IV is not difficult to fly, but it is different; like a Yankee is different from a Cessna, or a Cub is different from a Cherokee. A pilot who is used to the differences between a Cessna and a Cub is ready to adapt to the differences in a Mark IV. The Mark IV has entirely conventional flying qualities. However, its responsiveness is quicker and its landing speed is faster than most light training aircraft. It should not be considered as a training airplane to develop basic flight proficiency. The Mark IV ranks with the best tricycle gear types for ground stability and has none of the ground-looping tendencies of the taildraggers.

The requirement for a variety of experience applies to checkout in any type of new aircraft, not only to the Mark IV. Of course, the Mark IV is an ideal airplane for checking out other Mark IV pilots, or even Long EZ pilots, because of the dual controls. The pilot to be checked out can first ride as a passenger on the side he will later solo from. The following criteria is strongly recommended for initial pilot checkout:

- 1) Checkout should not be done in gusty winds, particularly crosswind conditions.
- 2) Use a runway at least 4,000 ft. long for initial checkouts. The beginning Mark IV pilot often finds himself fast on approach and the airplane is so clean that it is easy to use up a lot of runway in the flare.
- 3) Give the pilot a ride or two as a passenger. This gives them a first-hand look at the aircraft's performance envelope and general flying qualities. Trim the airplane up and let them fly it. This will give them an appreciation of the airplane's natural stability. Show them the use of the trim systems (pitch and roll). Let them get used to the pitch and roll feel. Let them

follow through while you shoot some landings and takeoffs. Do not transition them to their first solo flight until they fly the aircraft smoothly and confidently from the passenger seat.

- 4) Their first solo flight should be without any passengers and they should fly from the same seat they were checked out in.
- 5) Add ballast to the nose compartment so the c. g. will be in the forward portion of the flight box recommended for the first flight (see [Weight & Balance](#)), preferably in approximately the same location as during their checkout.
- 6) Briefing must emphasize that the aircraft should never be rotated past the angle that places the canard on the horizon for takeoff or landing.
- 7) The pilot being checked out must have a minimum of 10 hours each in at least two types of aircraft in the last 4 months (5 in the last 30 days) and feel competent and comfortable in them during marginal conditions, such as crosswind landings near demonstrated limits etc.

Since the Mark IV performs much like the Long-EZ, the experience of Rutan Aircraft Factory (RAF) in checking out new Long-EZ pilots might be helpful. Keep in mind that they did not have the luxury of a full-dual checkout in the front seat:

"Initially some of the pilots checked out by RAF tended to do the following on their first takeoff: Immediately after lift-off, they would level off or descend, then re-establish a normal climb. We have found that this is caused by the unusual visual cue provided by the canard. Even though the climb angle is similar to other light planes, the canard gives the pilot the impression that he has over-rotated. Since we found this was the cause, we have told pilots the following and have found that the pitch "bobble" no longer occurs: 'Rotate smoothly to lift-off at 65 KIAS. If you think you have over-rotated, do not overreact. Don't shove the stick forward. Hold the liftoff attitude and the airplane will accelerate to 80 KIAS for climb.

"Occasionally a new Long-EZ pilot will tend to make a "full stall" landing or flare too high. We tell him that if he has made the approach at the correct speed and pulls

power to idle before the flare, he should not spend a lot of time in the flare. He should make a complete flare, and then fly the airplane down onto the runway."

For further information on checkouts, refer to [FLIGHT TEST PROCEDURES](#), Appendix II.

Weight and Balance

Every aircraft has an acceptable c.g. (center of gravity) range which is determined by the designer and confirmed by flight testing, within which the aircraft has positive stability, predictable performance and can operate safely. It is a basic requirement for obtaining a pilot's license that the pilot be familiar with c.g. calculations and be able to perform them correctly. It is the responsibility of every pilot to load his aircraft in such a way that the c.g. is in the acceptable range, using ballast if necessary. Empty weight and empty c.g. location are determined before the first flight by weighing. It must be updated whenever new, permanent equipment is added; i.e., wheel pants, spinner, different propeller, instruments, upholstery, etc. This update may be performed using an actual weighing, or by math if the weights and stations of the removed or new equipment is well known and understood.

W&B methodology is shown below. Be sure you use empty weight and moment data for your aircraft determined by actual weighing. There can be considerable builder differences, depending upon workmanship and equipment. Use the mathematical formulae and a pocket calculator or spreadsheet with the weight vs. fuselage station chart. Add up the weight and moment totals for your load as shown in the sample problems. Then divide the total moment by the total weight, to get the loaded c.g. position fuselage station (inches aft of the datum, F.S. 0.0).

FORMULA

$$c.g. position = \frac{\text{total of all moments}}{\text{total loaded weight}}$$

Total of all moments is the total of the following:

Empty moment	(determined after weighing aircraft)
Pilot moment	(pilot weight x 57)
Front passenger moment	(passenger weight x 57)
Nose ballast moment	(weight x 11.5)

Cozy Mark IV Owner's Manual - N83MZ

Rear passenger(s) moment (passenger weight x 101)

Baggage moment (baggage weight x 90)

Fuel moment (fuel in gallons x 6 x 103)

Oil moment (oil in quarts x 1 x 142)

Total loaded weight = empty weight + pilot + passengers + nose ballast + fuel + oil

NOTE: The spreadsheet used for the following figures and to use for calculation is [N83MZ-W&B-for-POH](#):

Marc J. Zeitlin A&P #3052594

**COZY MKIV
N83MZ**

May 7, 2023

CG LIMITS: Front: 97.5 in. Flight Ballast Station 13 in.
 Rear: 102.0 in.
MGW LIMIT: 2,175 lb.

Calculation Area			
	Weight	Station	Moment
Empty	1,259	110.5	139,079
Fuel	0	103.0	0
Pilot/CoPilot	0	57.0	0
Rear Seats	0	101.0	0
Baggage	0	90.0	0
Flight Ballast	43.5	13.0	566
	1,302	107.2	139,645

Empty Weight			
	Weight	Station	Moment
Right Main	639	110.0	70,334
Left Main	623	110.0	68,574
Nose	39	18.7	737
As Weighed	1,302	107.2	139,645
Fuel	0	103.0	0
Equiv. W&B Ballast	43.5	13	566
Empty	1,259	110.5	139,079

Figure 4: N83MZ Empty Airplane Weight & Balance

Cozy Mark IV Owner's Manual - N83MZ

Light Pilot w/ballast – Full Fuel			
	Weight	Station	Moment
Empty	1,259	110.5	139,079
Fuel	348	103.0	35,844
Pilot/CoPilot	160	57.0	9,120
Rear Seats	0	101.0	0
Baggage	0	90.0	0
Flight Ballast	43.5	13.0	566
	1,810	102.0	184,609

Light Pilot w/ballast – Low Fuel			
	Weight	Station	Moment
Empty	1,259	110.5	139,079
Fuel	30	103.0	3,090
Pilot/CoPilot	160	57.0	9,120
Rear Seats	0	101.0	0
Baggage	0	90.0	0
Flight Ballast	43.5	13.0	566
	1,492	101.8	151,855

Light Pilot no ballast – Full Fuel			
	Weight	Station	Moment
Empty	1,259	110.5	139,079
Fuel	348	103.0	35,844
Pilot/CoPilot	238	57.0	13,566
Rear Seats	330	101.0	33,330
Baggage	0	90.0	0
Flight Ballast	0.0	13.0	0
	2,175	102.0	221,819

Light Pilot no ballast – Low Fuel			
	Weight	Station	Moment
Empty	1,259	110.5	139,079
Fuel	30	103.0	3,090
Pilot/CoPilot	238	57.0	13,566
Rear Seats	330	101.0	33,330
Baggage	0	90.0	0
Flight Ballast	0.0	13.0	0
	1,857	101.8	189,065

Heavy Pilot – Full Fuel			
	Weight	Station	Moment
Empty	1,259	110.5	139,079
Fuel	348	103.0	35,844
Pilot/CoPilot	407	57.0	23,199
Rear Seats	0	101.0	0
Baggage	0	90.0	0
Flight Ballast	0	13.0	0
	2,014	98.4	198,122

Heavy Pilot – Low Fuel			
	Weight	Station	Moment
Empty	1,259	110.5	139,079
Fuel	30	103.0	3,090
Pilot/CoPilot	407	57.0	23,199
Rear Seats	0	101.0	0
Baggage	0	90.0	0
Flight Ballast	0	13.0	0
	1,696	97.5	165,368

Figure 5: N83MZ Typical Configurations

Weight & CG Limits

- MGW:** 2,175 lb.
- Forward CG Limit:** 97.5 in.
- Aft CG Limit:** 102 in.
- First Flight MGW:** 1,550 lb.
- First Flight Forward CG Limit:** 99 in.
- First Flight Aft CG Limit:** 100.5 in.

APPENDIX I:

(Initial Systems Checkout)

Before initial taxi testing is begun, each new aircraft should have a very complete inspection and functional test of its flight systems. Factory built aircraft are given a similar series of tests before the pilot ever sees his new mount; however, the Mark IV owner must perform these production tests himself. The following procedure should be used for initial system checkout and for each annual inspection.

GENERAL

- Check all fasteners for proper security and safetying
- Check canard attach bolts for security and proper installation
- Check wing attach bolts for tightness and proper number of threads showing
- Check wing incidence, canard incidence, rudder, ailerons and elevator deflections
- Canard incidence $+0.3 \pm 0.3$ deg.
(Use canard incidence templates B & C)
- Wing incidence $Zero \pm 0.5$ deg.
(Use wing incidence templates. Wings must be within 0.3 deg. incidence of each other)
- Rudder Travel $4.25" \pm 0.25"$
Measure at the bottom of the rudder at the trailing edge while the pilot holds full rudder pedal and someone else applies a 5 lb. force inboard on the rudder trailing edge, to take any "slack" out of the system
- Elevator travel (trailing edge down) 28 ± 2.0 deg
(trailing edge up) 14 ± 1.5 deg
- Aileron travel $2.1" \pm 0.3"$
Measure at the inboard trailing edge, both up and down. When in the neutral position, both aileron trailing edges must be aligned with wing trailing edges

CONTROL SYSTEM

- Check that canopy sponge seals are in place and that the canopy locking handle is adjusted so it must be forced hard forward to lock. This is extremely important to eliminate any possibility of it being bumped open in flight
- Check elevator and aileron pushrods for proper installation (spacers, washers, bolts, locknuts, clevis pins, and safety clips installed properly)
- Check elevator and aileron pushrods for freedom of movement through-out control travel
- Check elevator and aileron for freedom of movement throughout range without binding or chafing
- Check pitch and roll trim mechanisms for proper function, and freedom of movement
- Check rudder pedals for freedom of movement, cable attachment, and positive return to neutral
- Check rudder pulleys for free rotation and cable guard installation (the eight cotter pins through the pulley brackets)
- Check rudder cable clearance throughout control travel
- Check brake actuating mechanism for freedom
- Check all rod ends. Reject any with evidence of bent tangs
- Check elevators for proper mass balance. They should hang nose down when suspended from the hinge pin by a fine wire (after painting). Weight should be evenly distributed between inboard and outboard locations. Maximum elevator weight with mass balances installed is 3.9 lbs. each
- Check ailerons for proper mass balance. When suspended from the hinge pivots, the ailerons must hang between the angle that makes the bottom surface level and the angle that makes the top surface level (after painting)
- Check for 1/16" minimum clearances around all mass balances. Binding can occur at elevated load factors if the clearance is too tight

LANDING GEAR

Main Gear

- Double check that all attach bolts and axle bolts are installed and secured
- Check tires for proper inflation pressure. The 5.00 x 5 10-ply tires on the main gear should be inflated to 60 psi. Wait 24 hours and check for leaks
- Adjust brakes and test for proper function. Service with DOT-5 fluid as required. Pressure bleed by filling from the bottom up to the master cylinder. Recheck rudder travel to verify maximum limit is not exceeded
- Check for proper main tire toe-in which should be 1/4 to 1/2 degrees per side
- Wheel bearings should be packed with grease
- Brake calipers should move freely and be safeteyed

Nose Gear

- Nose gear tire inflation: 50 psi for 4-ply tires and 70 psi for 6 or 8 ply tires
- Wheel bearings should be greased
- Axle nut should be tight and cotter pinned - wheel should rotate on bearings, not bearings on axle
- Check the shimmy damper for friction adjustment. Side force to rotate pivot should be at least two to four pounds applied at the axle - as much as possible without restricting ground steering
- Check safeying and security on all actuating mechanism hardware
- Cycle gear to verify proper function
- Verify nose gear warning micro-switches activate appropriately

INSTRUMENTATION

- Cylinder Head Temperature and Oil Temperature - These gauges should be accurately calibrated before use. Dip the probes in hot oil and check the oil temperature with a candy thermometer
- Pitot & Static System - Check for leaks
- Oil Pressure, Tachometer, Fuel Pressure - Verify proper function during initial engine run-up

POWERPLANT

- Check propeller bolts for proper torque. Check with Persson Propellers for the correct torque values. For N83MZ, with a Hertzler/Persson Silver Bullet Propeller, Belleville washers and 1/2" bolts, torque to 30 ft-lbs. Make sure propeller bolts are safetied in pairs. Ensure that the belleville washers are installed in the proper <><> orientation
- Check propeller for absence of cracks and blades tracking within 1/16"
- Check engine mount bolts for security and safety
- Check oil level > 4 qt and <6 qt
- Check throttle, & oil cooler louver controls for security and function
- Check ignition wiring. Be sure ignitions are cold when the switches are off
- Check that cowling baffles fit tightly all around the engine and cowling. If not, there will be air leakage; insufficient cooling and engine overheating may result

FUEL SYSTEM

- Check that grounding wires are attached to the fuel caps and the seal securely and the vent system is clear and without leaks
- Check freedom of fuel valve. If it requires more than 10 lbs. of force at the handle, either overhaul it or replace it
- Check you fuel selector valve for proper function (left, right, and off)
- Calibrate your fuel gauges with the aircraft level (flight attitude)

FUEL GRADE CAUTION

Under no circumstances should fuel of a lower octane rating than that specified by the manufacturer for your engine be used. It will result in power loss, possibly detonation at high power settings, and possible catastrophic engine failure.

Non-100LL FUEL CAUTION

Use non-100LL fuel only if tested and proven to have no deleterious effects on either the epoxy in the tanks or the seals or components in the fuel system.

WEIGHT AND BALANCE

Final weighing before initial flight tests is very important and should be done carefully. The measurements taken should be recorded in the airframe log book and used in the weight and balance data kept aboard your airplane (See previous [Weight and Balance](#)).

You will need three scales. Try to find someone with electronic scales designed specifically for weighing aircraft. A bathroom scale is **not** suitable. You will also need a level, a 12 ft. decimal tape measure, a plumb bob and line, chalk and chalk line to mark the hangar floor, and some ballast weight to keep the nose down on the scales with nose gear extended. Check the accuracy of the scales by weighing an item whose weight is already known.

You should roll the main gear up onto the scale platform rather than lifting it, to avoid side-loading the scale. If you have only one scale and plan to measure just one gear at a time, the other gear(s) must be rolled up onto ramps of the same height so the aircraft will be dead level fore and aft, and side to side, using the top longerons as reference. Put the ballast in the nose ballast compartment (F.S. of 11.5). Close the canopy. Record the scale readings with the airplane empty (no fuel, no oil, no pilot, no baggage, etc.), except for whatever ballast is required.

After weighing, with the airplane off the scales but still level, use your plumb bob and line to mark the aircraft centerline on the floor, and then the position of the nose wheel axle, canard leading edge (both sides), main gear axles (both sides) and wing root leading edge (both sides). Then roll the airplane out of the way, translate the plumb bob points to the aircraft centerline, assign F.S. 113.9 to the wing root leading edge and measure and record all of the other points (see example, next page).

Note that the reference point for all c.g. calculations and limits is the wing root L.E., which is set at F.S. 113.9 in. The forward face of the instrument panel should be approximately F.S. 41.25. Record the exact location in the airplane. The main gear should be at F.S. 110 ± 0.5 to allow correct rotation speed and ground handling. Canard L.E. should be at F.S. 18.6 ± 0.5 for correct flying qualities.

When ballasting the aircraft for the initial flight testing, and for initial pilot checkouts, the weight and c.g. must fall in the first flight box. If one must be exceeded, overweight is preferable to an aft c.g. condition.

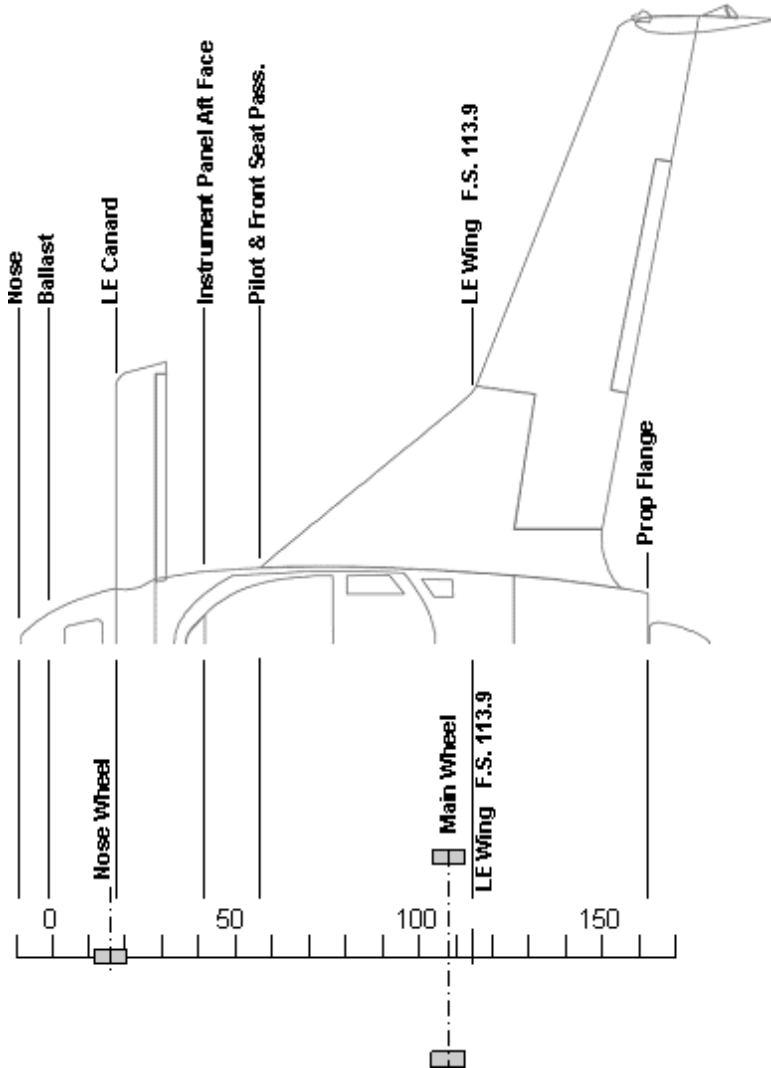

Lay out fuselage stations on the floor under the aircraft along the aircraft centerline. Establish scale using LE wings as reference at F.S. 113.9”.

EMPTY WEIGHT & C.G. LOCATION

The calculation of empty weight and c.g. location is straight-forward. Empty weight is the total of all weights measured on the scales, less ballast and/or tares (boards or shims placed below wheels on scales).

Each net weight times its F.S. position gives its moment, and the sum of the moments divided by the net weight gives the c.g. location.

WEIGHT AND BALANCE CAUTION

Whenever you add equipment to your aircraft, after the initial weighing, record the weight, fuselage station and moment in your aircraft log book and adjust the aircraft empty weight, e.g. and moment accordingly. The same holds true if you relocate equipment, like the battery, etc.

MAXIMUM GROSS WEIGHT CAUTION

Operations above the designed gross weight limitations as stated in this manual, is a high risk activity and an extremely hazardous practice.

MGW NOTE

A maximum gross weight, for takeoff only, of 2,175 lbs. may be used, but only under the following limitations:

- 1) Taxi and take off only on a smooth, hard surface. Use 8 or 10 ply tires or equivalent with >60 psi inflation
- 2) Maximum landing weight limited to 2050 lbs.
- 3) Refer to gross weight takeoff distance. See chart. Lift off at 80 KIAS and climb at 90 KIAS
- 4) Maneuvers limited to sub-normal category (+3.5g, -1g). No abrupt maneuvers
- 5) Before conducting maximum-gross operation, the pilot should be a proficient and competent Mark IV pilot with at least 50 landings in the aircraft. The pilot should not attempt maximum-gross operations at high density altitudes or gusty crosswinds. Maximum crosswind component is 8 knots.

- 6) Maximum gross weight operations should not be considered a routine operation since the chance of surviving an off-airport forced landing diminishes rapidly as weight goes up. It should only be considered on those rare occasions when a long-range, full-fuel, full-baggage, four-place operation is necessary. Routine operations above 2,050 lbs. gross weight are not recommended

APPENDIX II: (Flight Test Procedures)

Along with the procedures described below, use FAA Advisory Circular [AC90-89C](#) for general guidance, and Kevin Walsh's excellent [Phase I Test Protocol](#) for specific test card development for the Phase I period.

As you complete the final checkout on your new airplane, you are going to be hot to fly your first flight. You may push a little too hard at the last minute and try to fly prematurely, possibly with something wrong with your airplane. To avoid this "homebuilder syndrome", give the only key to your bird to a close friend (preferably one who really likes you and to whom you owe money) and give the absolute authority to say "go" or "no-go" to your initial flight tests. With all the other things you are thinking about, it is best to give the decision (of whether the airplane is ready) to someone else. If you really get a bad case of "homebuilder's syndrome" your friendship may be strained somewhat, but you will be able to make up after you have tested your new bird safely. A little champagne seems to help!

This "homebuilder's syndrome" has been a major factor in many first-flight accidents. Typical of this problem is where an individual spends all his time and money building his airplane and, for several years, lets his flying proficiency lapse. Very typically we find a finished homebuilt with the owner/pilot seriously lacking in pilot proficiency. In one case the pilot who tried to fly his first flight on his homebuilt had only one flight in the last two years!!! Another problem surfaces about the time the aircraft is ready to fly - "Ego", that is, "I built the machine, I'll fly it. After all, who knows more about my machine than me? I built it!" The homebuilder is understandably proud of his creation and becomes very possessive. So, we find the proud builder/pilot at the end of the runway "ready" for takeoff with possibly a bad case of "homebuilder syndrome". But he won't know it until just after lift off when he finds himself suddenly thrust into an environment he is ill-prepared to handle.

The best remedy for "homebuilder syndrome" is to accept help on your flight testing from an experienced Mark IV pilot. Then get a good checkout from them.

GROUND TESTING

Don't just race out and fly your airplane. You will spend a while checking out all of your systems on the ground before you leap off on the first flight. The first order of business is to check out your engine system thoroughly. Ground run it for an hour or so at low to medium power. Run it with the top cowling off and look for excessive vibration, unsafetied hardware, leaky fuel lines, or anything else unpleasant. After this initial run-in period (or the manufacturer's recommended run-in for new or overhauled engines), check everything over very carefully. Recheck the exhaust nuts for torque, look for leaks around gaskets, loose clamps, check fit of cowling baffles, etc. Check everything thoroughly before you button up the cowling to begin taxi tests. Be sure the engine compartment is clean. Check for nuts, washers, bits of safety wire, etc. because in a pusher, everything that comes off goes right through the propeller.

And last of all, are you sure you have complied with all the details in [APPENDIX I: \(Initial Systems Checkout\)](#).

LOW SPEED TAXI

Make all initial taxi/runway flights without wheel pants for better brake cooling.

Refer to "[PILOT POSITION](#)", to set up the seat for correct visibility. Low speed taxi is defined as that slower than required to lift the nose wheel off the ground, i.e. 40 kts. Spend at least a full hour doing low speed taxi to fully familiarize yourself with the cockpit environment and to thoroughly check the engine, brakes, controls, landing gear, etc.

40 KIAS is sufficient speed to evaluate rudder steering and brake effectiveness. You may find that extensive taxiing can overheat the brakes. At 40 KIAS you will note that the floppy feel of the control stick is gone and air loads now provide a comfortable centering feel.

Recheck that your weight and balance is within the "first flight" box on the diagram. Recheck wing and canard incidences and control travel and freedom before proceeding. Now is the time for the final FAA inspection and issuance of your airworthiness certificate.

HIGH SPEED TAXI & NOSEWHEEL LIFTOFFS

Before conducting the following tests with your new Mark IV, do all of them first with two other different airplanes in which you are proficient. These maneuvers (nose wheel lift offs at low power) are a little strange to the average pilot. Doing them in a familiar airplane takes the strangeness out of the maneuver and better prepares you to do them in a new airplane. It also gives you a first-hand look at runway length requirements and wind conditions.

Some of the following requirements and procedures may seem excessive. This is not due to any special feature of the Mark IV; we feel they should be required of any homebuilt during its initial testing. The safety record of homebuilt airplanes during first flights is not as good as it could be if the owners and pilots would follow the following cautious procedures during initial testing.

- Weather - wind calm or smooth wind straight down the runway. Smooth air - Check turbulence in another airplane
- Runway - at least 3,500 ft, preferably over 4,000 ft. - at high DA's, more may be required
- Fuel - 10 gallons each tank
- Pilot - see pilot experience requirements for absolute minimum criteria. Do not test fly a new airplane while fatigued: Go home, get some dinner, sleep; you're more alert in the morning

The reason for the long runway requirement is to allow you to do nose wheel lift-offs and decelerations without concern for stopping distance or brake heating. The air must be smooth and without crosswind. Set the pitch trim for takeoff. Set neutral roll trim.

The purpose of this phase of testing is to evaluate the aircraft's performance and trim during high speed taxi/nose wheel lift-offs, to acquaint the pilot with the pitch and yaw characteristics of the

Mark IV, and most importantly to give them the correct visual cue of zero height to allow him to judge flare height on his first landing. The pilot should spend enough time just below rotation speed to be thoroughly proficient and comfortable with the unique Mark IV rudder system. There should be no tendency for the pilot to inadvertently push/deploy both rudders at the same time, unless during braking.

Next step is to practice speed control before attempting nose wheel lift-offs. It's important to be able to control speed accurately so as not to get airborne inadvertently. You will find that once a speed is attained, it takes very little power to maintain it. Practice accelerating to and maintaining different target speeds (30, 40, 50, & 60 KIAS). Do not rotate.

You will find that once the target speed is reached, you must reduce power to idle or just a bit above to keep from exceeding it. Be proficient and comfortable in holding speed before moving on to nose wheel lift-offs. The aircraft will rotate at different speeds depending on gross weight and center of gravity. To determine rotation speed, accelerate to 40 KIAS, set power to maintain speed (close to idle), and then attempt to rotate. If 40 KIAS is too slow to rotate, then go back to the start and try 45 KIAS, etc. Find the speed that will just rotate the nose (about 60 KIAS), reduce power to near idle and practice holding the nose at a predetermined position. Be careful not to over-rotate. Always keep the canard well below the horizon. The pilot should not allow the aircraft to exceed 60 KIAS or rotate to a point of becoming airborne during this exercise.

When you've done enough runs down the runway so that you can comfortably, smoothly, and precisely control speed, pitch, and yaw with the nose wheel off the ground, you should be ready for the first flight.

FIRST FLIGHT

You should be proficient in rudder operation and positive control of pitch to be ready for the "big one". But be sure you review and understand the following:

The Mark IV does not fly like a Cessna 150 or some other sluggish trainer. The Mark IV is a high-performance, responsive aircraft with differences. It has a side stick and the pilot should keep his forearm on the arm rest and use his wrist to control pitch. Also, the rudders can both be deployed simultaneously and the pilot should be careful not to inadvertently do this in flight.

There are two differences in a Mark IV which must be thoroughly understood prior to flight:

1. The non-standard rudder pedals. Be sure not to inadvertently deploy both rudders at the same time in flight. If you do this, one rudder will usually be out more than the other, producing unwanted yaw. The Mark IV rudders are quite effective. Adjust the pedals so your feet do not press the pedals naturally.
2. Pitch over-controlling. The novice pilot will expect the Mark IV to handle like a Cessna 150, or whatever he last flew. The experienced pilot knows that J-3 Cubs and Bonanzas handle differently and will make the transition easily. Spend enough time on the runway just above rotation speed, but below lift-off speed, and practice controlling pitch so you can put and hold the desired/selected pitch proficiently. Hold the forearm on the arm rest and control pitch with the wrist only. Do not over-rotate! The highest rotation you should see during this or a later flight is the canard up to, but **never** above the horizon. Better yet, keep it always at least 2 degrees below the horizon.

FIRST FLIGHT NOTE

If you are accustomed to flying with the stick in your right hand and the throttle in the left, make your first and subsequent flights sitting on the right side. Do not transition to the left side until you are thoroughly accustomed to the aircraft and familiar with its flying qualities. Transitioning to the left seat is not difficult, except you will have to concentrate on the fact that your left hand holds the stick for the first few landings. After that, it's very natural.

Remember, the first flight of your aircraft is just one baby step up from the lift-off that you've just completed, and is just the bare beginning of your flight test program. First flight should again be made under ideal weather conditions. The weight and c.g. position

should be within the limited envelope shown for initial flight tests. This will require adding ballast to the nose. First flight is not intended to demonstrate the capability of your aircraft or of the pilot and should be flown very conservatively. Leave the gear down and give yourself one less thing to worry about. Limit your airspeed to a range of from 80 KIAS to 140 KIAS. Stay over the airport, and resist the urge to buzz your observers. Buzz jobs on the first flight are done by fools, never by professional test pilots.

During your climb out, set your pitch and roll trims to trim the airplane for hands-off flight. This will be a handy reminder of trim direction, if the airplane needs adjustment. You will notice a small roll trim change when you reduce power. The airplane will require more right trim with power off. Limit your first flight to feeling out roll, pitch, and yaw responses and checking engine operation, temperatures, pressures, etc. Make your approach at 80 KIAS and make a slightly fast touchdown (75 KIAS), leaving slower speed touchdowns for later in the test program.

After this first flight, make a thorough system check and clean and flush the fuel filters.

ENVELOPE EXPANSION

With the first flight completed and any squawks resolved, you are ready to expand your flight envelope. Do not promptly charge out and test-fly your aircraft at the extreme c.g. position and weights shown. Expand your envelope in small increments. Remember, you have to spend 40 hours in your test area, so put the time to good use and do a professional job of flight testing. Before expanding the weight and c.g. range shown for initial testing, spend a few hours and become thoroughly comfortable in your piloting tasks. When you feel at home in the airplane, begin your expansion of the weight, c.g. position, load factor, and airspeed ranges. Don't feel obligated to expand into the full ranges shown in the plans and in this handbook. Expand your limitations slowly, and if you reach a point that you feel uncomfortable, stop! The ranges shown are those demonstrated by the designer. Feel free to restrict your airplane as you determine in your own testing; just don't exceed the design limits shown.

Do not assume that your aircraft will fly exactly the same as N44CZ, the Mark IV prototype, or N14CZ, the Mark IV plans model. Minor homebuilder construction tolerances can affect flying qualities and performance; for example, your aircraft may exhibit less or more stall margin. As with any aircraft, completely determine your stall characteristics at a safe altitude, and then operate your aircraft accordingly.

After you complete the expansion of the c.g. envelope on your aircraft, you may want to change the placarded minimum and maximum front seat weights to those with which you are comfortable.

Some words of general caution - A parachute is recommended for your flight testing. **Never leave a squawk unresolved**; find and fix problems as you encounter them. Airplanes usually give a hint of impending trouble. The problem is we pilots don't always listen. If something changes, a slight roughness or vibration, new oil leak, trim change, new squeak, etc, look until you find it. Don't rationalize it away. Have bunches of fun!

FLIGHT - FLUTTER ENVELOPE EXPANSION

Before you exceed 140 KIAS, you should be absolutely certain your elevators and ailerons are balanced per specs, you should be wearing a parachute, and you should be at a height of at least 8,000 ft. AGL. You should expand the airspeed envelope in increments of not more than 5 knots. At each increment, access the damping of the controls as follows: Kick a rudder pedal and jab the stick left, right, forward and aft. After each input, the controls should immediately return to trim, and any structural motion should damp within one cycle. This will require at least 3 or 4 dives, climbing back to altitude between dives. Do not expand airspeed in the dive when below 8,000 ft. AGL. Use care to not over speed the engine RPM. If you have just increased speed and find lower damping (i.e., the structure or controls shake more after the jab than at the 5-knot lower speed), do not continue to higher speeds. Recheck balance and weights of control surfaces. Solve any suspected cause of low damping before expanding airspeed. Expand speed to at least 1.1X the red-line (V_{NE}) speed you desire

to place on your aircraft, up to, but not exceeding 211 KIAS (190 KIAS/0.9). Placard your airspeed indicator with your red line.

FLUTTER TEST CAUTION

Friction or play in the pitch system can seriously degrade flying qualities. Eliminate all possible play and friction before first flight.

APPENDIX III: (Maintenance / Inspection)

COMPOSITE STRUCTURE

N83MZ is painted with a white acrylic urethane finish paint. UV radiation protection is provided by the solids in the primer and top coat, to protect the epoxy and foams from deterioration. Do not expose unprotected fiberglass to sunlight for extended periods. Unpainted areas should be retouched. The high surface durability and high safety margins designed into the Mark IV make it highly resistant to damage or fatigue. If the structure is damaged, it will show up as a crack in the paint. The strain characteristics of the material are such that it cannot fail internally without first cracking the paint. If damage is suspected due to a crack in the paint or a wrinkle in the skin, remove the paint around the crack (by sanding) and inspect the glass structure. Do not use enamel or lacquer paint remover. If the glass structure is damaged, it will have a white appearing ridge or notch, indicating torn (tension) or crushed (compression) fibers. If there is no glass damage, it will be smooth and transparent when sanded. If there is glass structure damage, repair as shown in the COZY MKIV **Plans Section I, Chapter 3**. Delaminations are rare, due to the proper design of joints (none have occurred in the prototype or first plans model). If a delamination occurs (skin trailing edge joints, etc.), spread the joint, sand the surfaces dull, trowel in wet flox, clamp back together, and let cure, or use the method in the construction manual.

Inspect suspected disbonds (areas where skin has separated from the foam) by tapping a quarter across the surface. A disbond will give a "dull thud" compared to the "sharp knock" of the adjacent good area. Disbonds may be repaired by injecting epoxy in one side of the area and venting the air out the opposite side, or in severe cases, by removal and replacement of the damaged skin.

PLEXIGLASS CANOPY

Because of the uniform frame and lack of metal fasteners, the Mark IV canopy is not as susceptible to cracks as the common aircraft plexiglass components. If a crack up to three inches does occur, stop drill it just outside the end of the crack with a 1/16" - 1/8" drill. Cracks longer than three inches require canopy replacement.

SCHEDULED MAINTENANCE/INSPECTIONS

Every Preflight (in addition to checklist items)

- Per Pre-Flight Checklist as found here:
[N83MZ Standard / Emergency Checklists](#)

Every 25 Hours

- Tires and Brakes - Remove wheel pants, check tire inflation (mains and nose 50 psi for 4-ply or 60 - 70 psi for 6 to 10-ply) and tire wear or cuts
- Check brake pads for wear
- Adjust nose wheel friction damper (>4 lbs. side force to swivel pivot)

Every 50 Hours

- Engine Cowl - Remove and check baffling for cracks
- Engine Oil and Filter Change (for spin-on filters)
- Check alternator belt for tension
- Exhaust system - Check for cracks, leaks and security. Carefully check the four exhaust gaskets for leaks. Never reuse an exhaust gasket
- Check crankcase breather PCV for blockage

EXHAUST SYSTEM NOTE

It is very important to avoid exhaust leaks if using a cabin heater to prevent fumes from entering the cockpit.

GENERAL 50 HOUR INSPECTION NOTE

Any contamination (foam, floc, dust, chips, etc.) left in the fuel system during construction could take 50 hours or more to be completely purged from the system. Check the filters often during the first 100 hours.

- Engine Mount - carefully check for cracks
- Air Filter - Check and clean/oil if dirty
- Brake Fluid Level - Check and fill master cylinders
- Cables, push-rods, fuel/oil lines and electrical wires. Check for chafing
- Fuel System - With electrical pump(s) on, pressure check for leaks
- Engine Run - Check for leaks, ignition drop, ignition turn-off

- Landing gear attach - Check for security/damage
- Nose gear - Check warning switch adjustment

Annual/100 Hours

Follow the Condition Inspection Checklist specific to N83MZ:

[N83MZ Condition Inspection Checklist](#)

COMPOSITE CONSTRUCTION NOTE

The composite material structural history in over 80,000 flying hours of similarly built aircraft (Long EZs and Vari-EZes) has never indicated a reason to be concerned about structural integrity. This annual structural inspection is important though, to indicate at an early stage any problem that needs attention.

Canard Removal

You can remove the canard by yourself, if necessary, but it helps to have an assistant. It takes about 10 minutes. Before you start, set up some padded sawhorses to set the canard on after removal. Tools required: 7/16" and 3/8" wrenches as well as needle-nose pliers.

Remove the rear nose door and weight the nose with ballast so the airplane won't tip over after the weight of the canard is removed. Disconnect the pitch trim and autopilot servo pushrods and remove the elevator pushrod quick disconnect pins on both sides of the cockpit.

Reaching in through the nose door forward of the canard, remove the two AN4 main canard attach bolts. These bolts screw into nut plates aft of the F-22 bulkhead, so no back-up wrench is required. Remove the bolts one at a time and label them (they may be different lengths), and record the number of washers used if more than one. There are no washers between the canard lift tabs and the bulkhead. Carefully lift the canard up and forward. Set the canard upside down on the supports you have provided. Be especially careful of the elevator pushrods so that they do not get bent by an unknowing passerby. Bent rod ends must be replaced.

Canard Installation

To reinstall the canard, slip the push rods into the fuselage and lower the canard into position. It will be necessary to hold the elevator's trailing edge up for the counterweights to clear bulkhead F-22. Hold the canard slightly leading edge high, engaging the alignment locating pins, and then slide the canard into position. Be careful not to get any antenna cable or wiring caught between the canard and the bulkhead. Add the correct washers under the AN4 bolt heads (not between the tab and the bulkhead) so the bolts will tighten without bottoming prematurely in the nut plate. Install the two AN4 canard main hold down bolts through the canard tabs into the nut plates on the aft side of the bulkhead.

Caution - bolt length may be different left/right. The bolts should be snugged well (about 50 - 75 in-lbs), but not over-tightened.

Reconnect the pitch trim and autopilot pushrods and elevator pushrod quick disconnects. Perform an operational check of trim and elevator systems. Recheck the AN4 bolts (in and torqued). Replace the rear nose door.

Wing Removal

Removal or installation of a wing requires one to three people. The operation will take about 30 minutes per wing. Tools required: Screwdriver, two 3/4" sockets with 3/8" drives, two 3" x 3/8" drive extensions and two 3/8" drive ratchets, as well as a 3/4" box end wrench. Remove the cowlings and disconnect the aileron pushrods and the rudder cables using the quick disconnects. Remove the three siliconed wing access attach hole covers on each wing. Support the wing tip and proceed to remove the three main wing attach bolts. The bolt heads for the two outboard bolts are trapped in a fixture inside the main spar and do not need a wrench on them. The single inboard bolt access is from inside the cowling area in the wing root. Access to the nut for this bolt is from inside the center section spar accessible from inside the back cockpit.

WING REMOVAL CAUTION

Be sure the nose is weighted / ballasted so the aircraft will not fall over backwards while you are working in the rear cockpit, especially after the canard is removed.

When the three main wing attach nuts are removed, support the wing at the tip and root, and slide it aft, off the aircraft.

Disconnect the nav/strobe light wires and the antenna cables, inside the wing root forward area.

Note the number and position of each incident (or sweep) shim washer on each bolt. These shims control the incidence (or sweep) of the wings and should be replaced **exactly** as they came off. If the bolts are also removed, label them (they may be of different lengths) and note the number and thickness of washers under each head. Set the wing on foam blocks or padded sawhorses to protect the surface from damage. The procedure is the same for both wings.

Wing Installation

To install the wings, use the reverse of the sequence explained above. Be sure the nose is weighted / ballasted so the weight of the wings won't tip the aircraft over on its tail. Recheck for the correct number of incidence shim washers on each bolt. Torque the bolts to between 150 and 200 in-lbs. Since you cannot get a torque wrench in the access wells, it's acceptable to just estimate the torque. These bolts are not highly stressed in this application (contrary to normal wing attach bolts) and accurate torquing is not required, just snug them up. Be sure to hook up and run a complete operational check of the ailerons, rudders, and lighting prior to flight.

APPENDIX IV: (FAA Records)

Records required for the Mark IV are essentially the same as for any production airplane (14 CFR Part 91). A valid airworthiness certificate and operating limitations as issued by a FAA inspector or DAR shall be displayed in the cockpit along with the aircraft registration certificate, weight and balance record. Airframe and engine log books are required as in any other aircraft. One area which is different from production aircraft is the method for maintaining records of major repairs and alterations. A major repair or alteration of the Mark IV requires following the procedure outlined in the operating limitations. Radio equipped aircraft must also have a valid FCC radiotelephone license for international flights.

FILL IN THE FOLLOWING TO COMPLETE THE DESIGN DOCUMENTATION OF YOUR AIRCRAFT:

1. This aircraft was built to the drawings described in the Cozy Mark IV manufacturing manual.

Yes X No

2. Co-Z Development Corp. has assigned serial number MK-386

APPENDIX V: (Performance Data)

To Determine Density Altitude

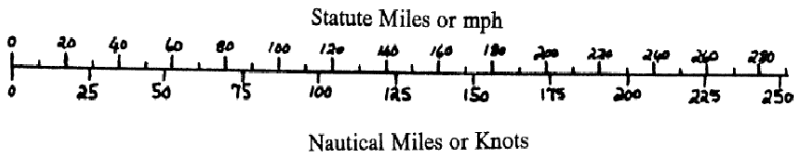
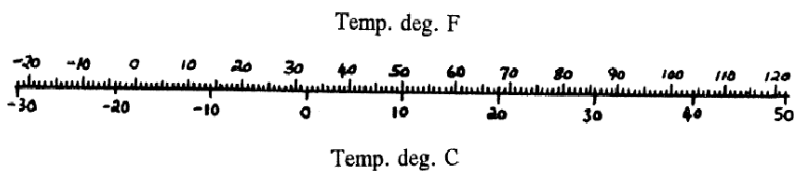
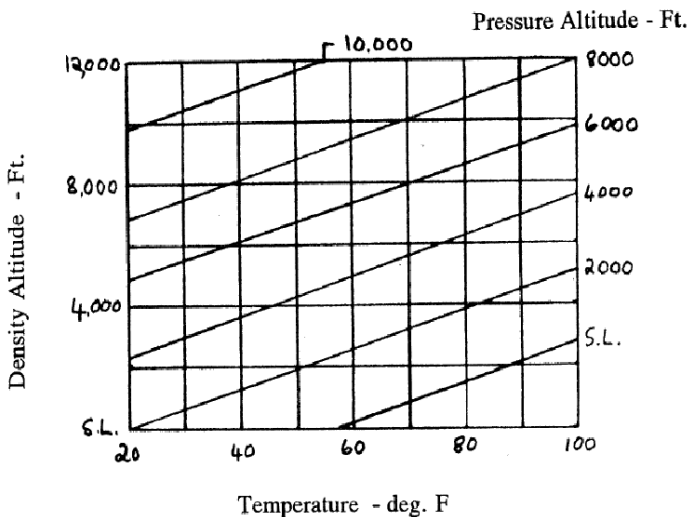

Prototype Takeoff Distance Curves

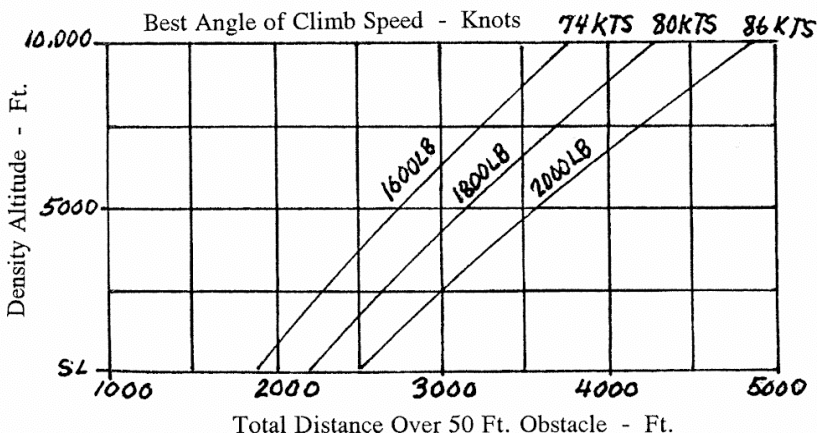
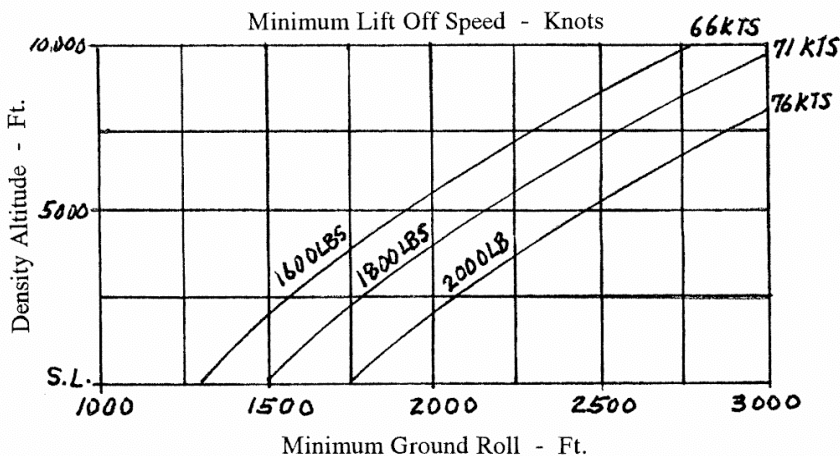

- Note:
1. Data for 180 hp Lyc 0-360 with 3-blade 64 x 76 Performance prop.
 2. Due to brake steering requirements, crosswinds can extend take off roll. For a 15 knot crosswind component, multiply take off roll data by 1.25.
 3. At forward c.g., the nosewheel lift off speed may be higher than the "minimum ground roll lift off speed". This can extend takeoff distance as much as 20% at max. forward c.g.

Prototype Climb Speed Curves

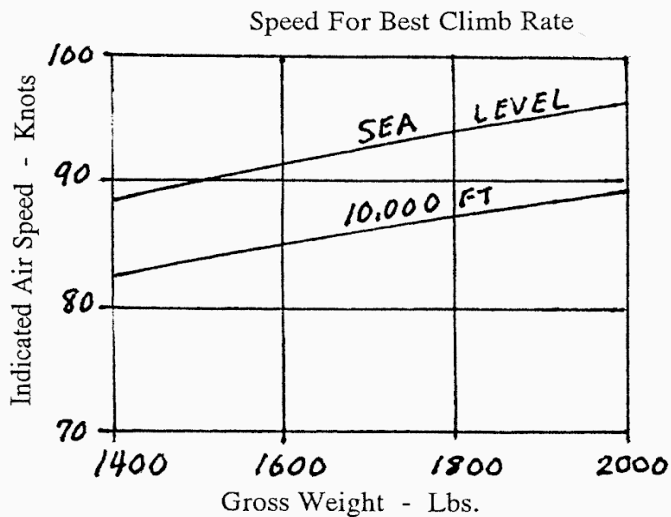

Note: For best cooling and visibility, increase speed 20 Knots.

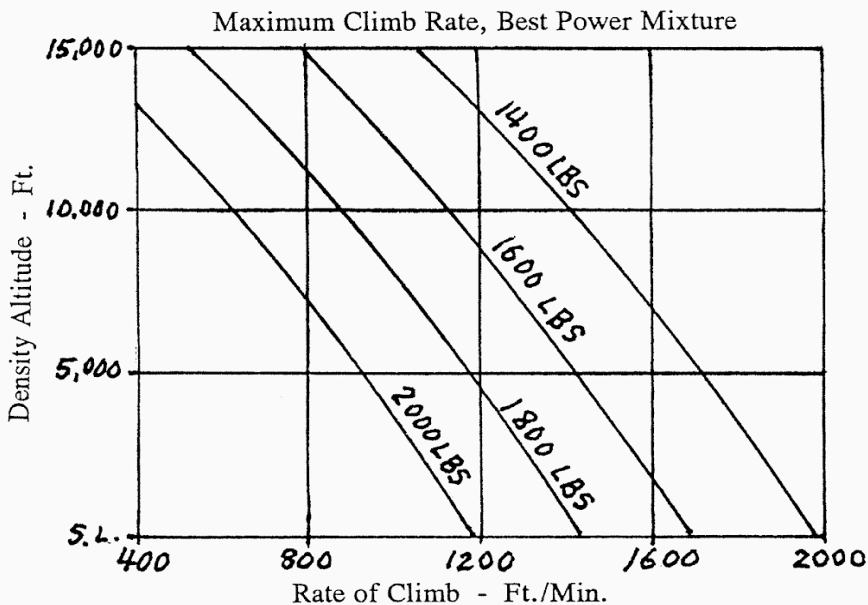

Note: Data for 180 hp Lyc 0-360 with 3-blade 64 x 76 Performance prop.

Maximum Speed – Level Flight

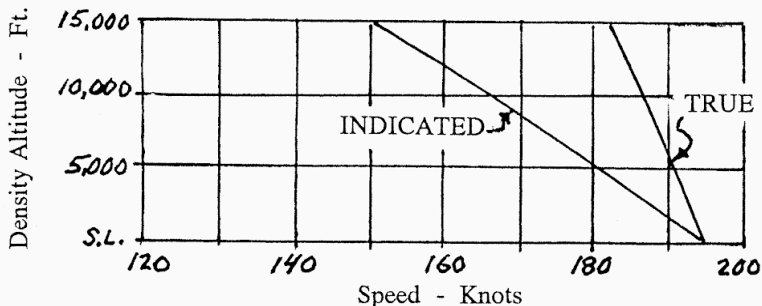

(With wheel pants - without, subtract 5 Knots)

CRUISE POWER

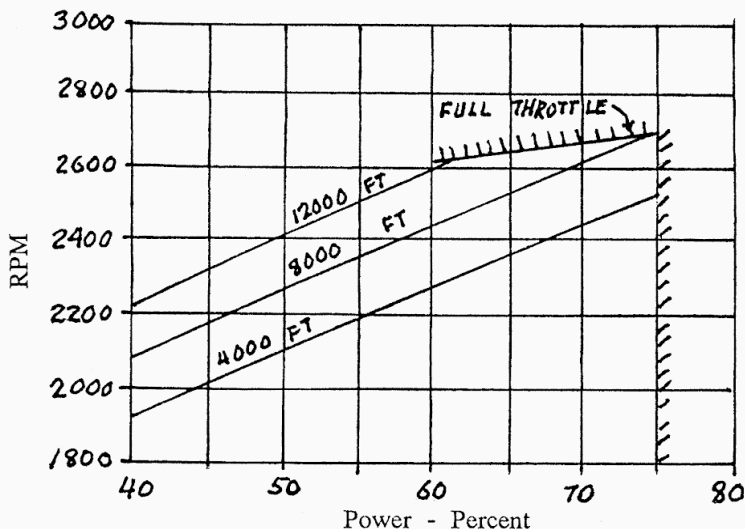

- Note:
1. Data for 180 hp Lyc 0-360 with 3-blade 64 x 76 Performance prop.
 2. Max. continuous cruise speed of 188 knots true is obtained at 8,000 Ft. with full throttle, 2700 rpm, and 10 gph. Economy cruise at 12,000 Ft., 50% power, 2400 rpm, and 6 gph results in 160 knots true.

Prototype Cruise Data Curves

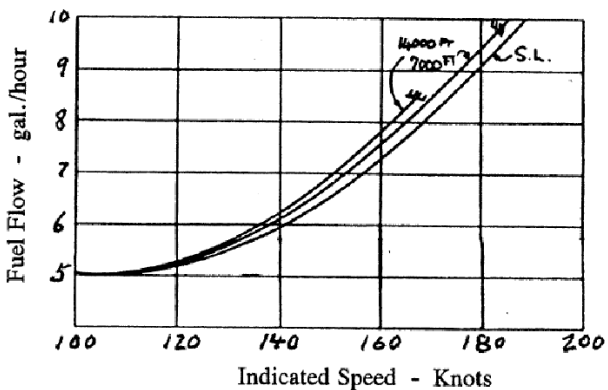
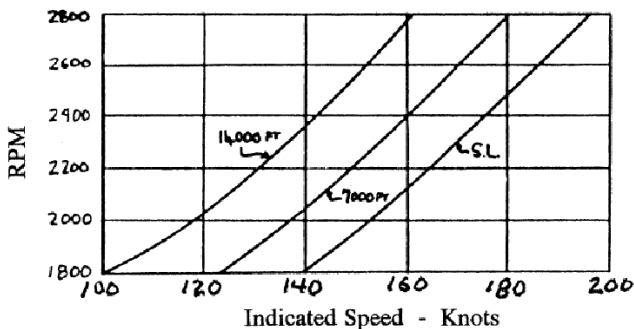
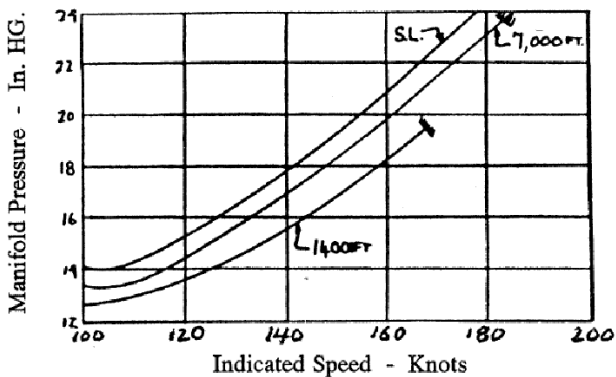

Note: Data for peak EGT mixture, Lyc 0-360 and 64x76 performance 3-blade propeller

Prototype Range Curves

To Calculate Range:

- 1) Subtract 5 gallons from total fuel, for reserve
- 2) Figure climb fuel and climb distance (top chart)
- 3) Subtract climb fuel and look up cruise range from lower chart
- 4) Total range is climb distance plus cruise range

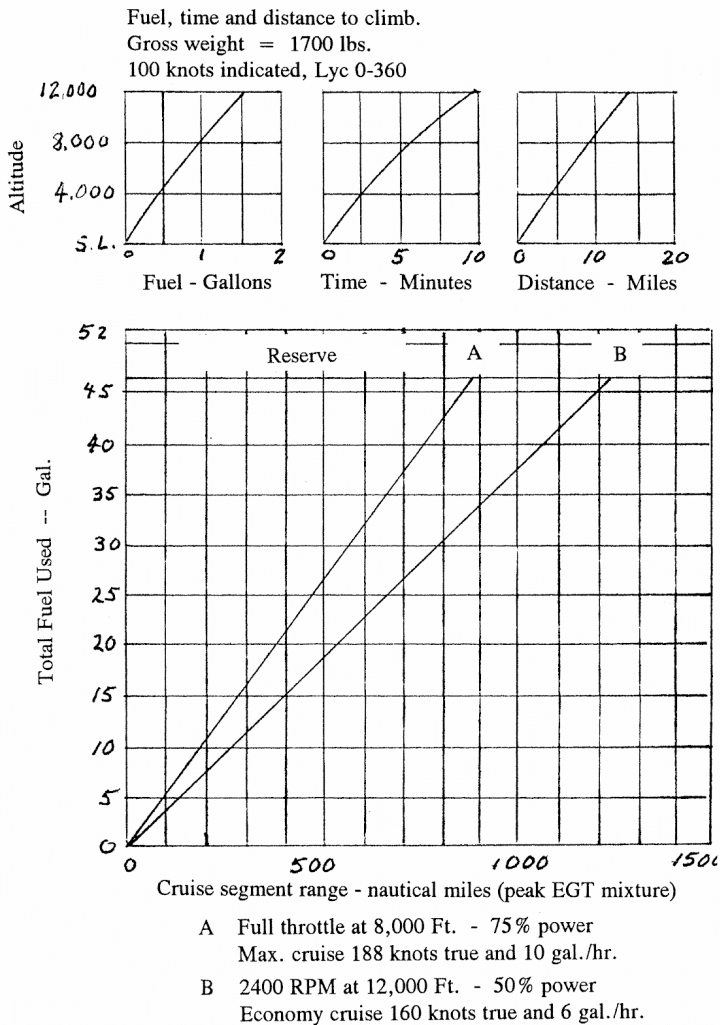

Prototype Glide – Gear Up Curves

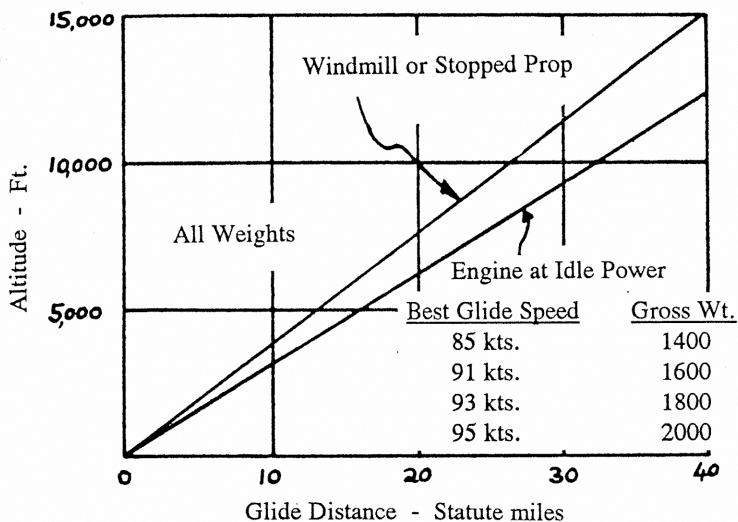

Prototype Sink Rate – Sea Level – Gear Up Curves

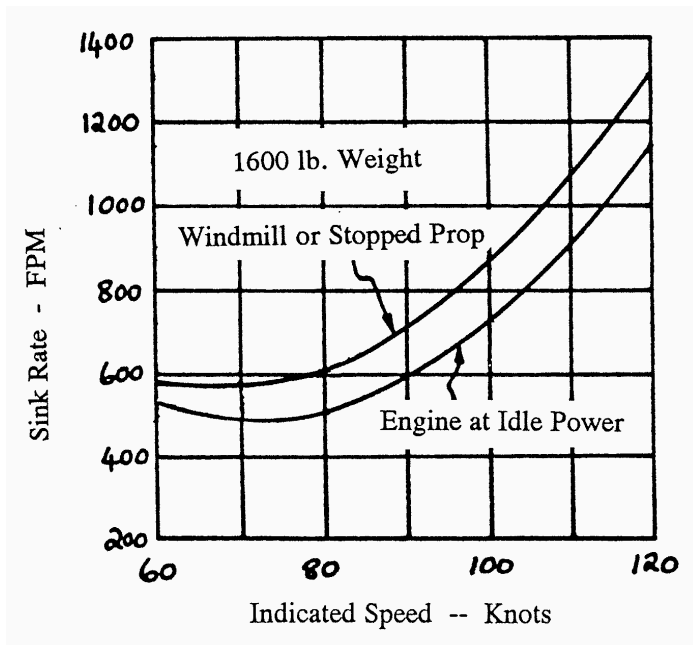

Prototype Landing Distance – LB Extended

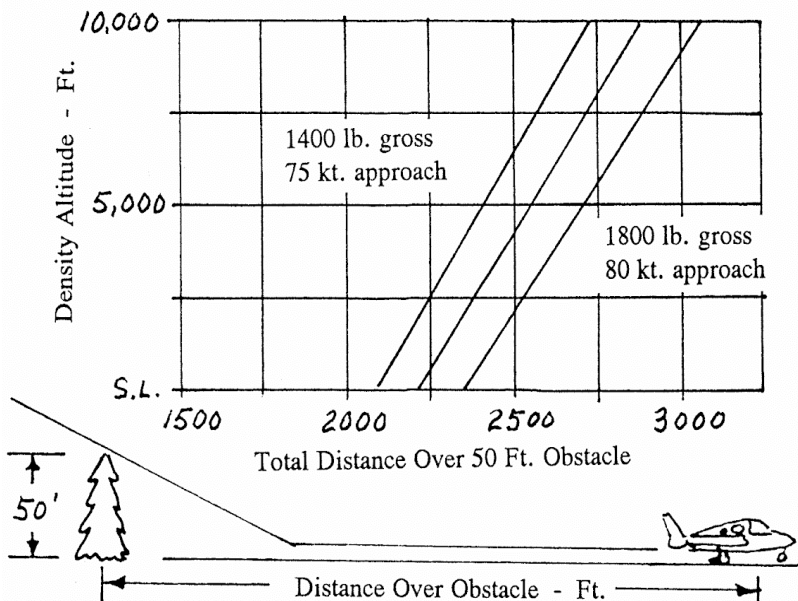
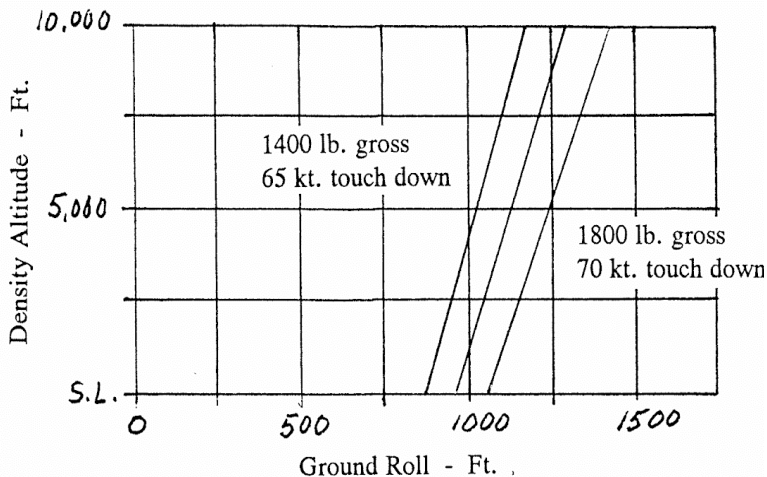

MARK IV Mandatory Changes

All Mandatory Changes are listed in the COZY newsletters as collated in the:

[“MKIV Plans Changes/Corrections”](#)

document.

EQUIPMENT LISTS

This list should consist of all those items of equipment installed in the aircraft. N83MZ's Aircraft Equipment List is maintained in the:

[**N83MZ Aircraft Logbook**](#)

and the Engine Equipment List is maintained in the:

[**N83MZ Engine Logbook**](#)

Pitch Stability Determination

Caution:

Before expanding your flight envelope, you should make sure your airplane has positive pitch stability; i.e., if you trim it for level flight and then either pull back on the stick or push it forward, upon release of the stick, it should return to level flight in no more than 3 oscillations.

Also, before expanding your flight envelope, you should double check that your canard is set at the right angle of incidence and/or your c.g. calculations are correct by comparing elevator position with the flight test data for our plans model shown below. If your elevator position differs by more than 1 degree, land and re-check your canard incidence using template "G", and re-check weight & balance and c.g. calculation. Do not fly until you have determined the problem and corrected it.

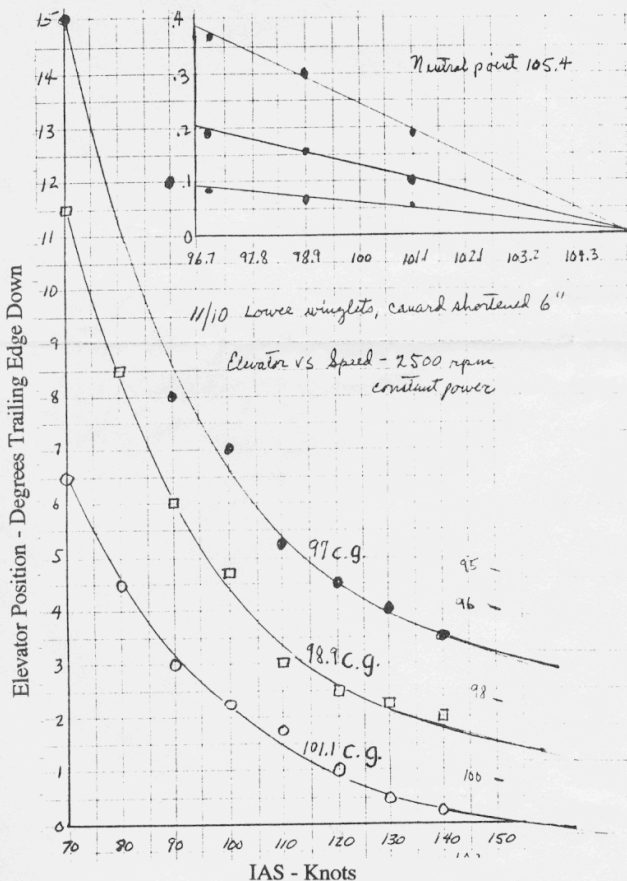

Revisions:

REV.	DATE	DESCRIPTION
01	January 23 rd , 2021	Original Release
02	September 27 th , 2022	<ul style="list-style-type: none">• Correct power off glide angle• Minor language mods• Misc. updates
03	June 9 th , 2023	<ul style="list-style-type: none">• Update for SDS system install• W&B revision• Minor corrections
04	December 24 th , 2023	<ul style="list-style-type: none">• Minor corrections/updates• Update +12V Power Schematic link• Add deep stall information• Add landing pattern slip recommendation for fuel tank on high side
05	November 3 rd , 2024	<ul style="list-style-type: none">• Modified fuel info, page 48